

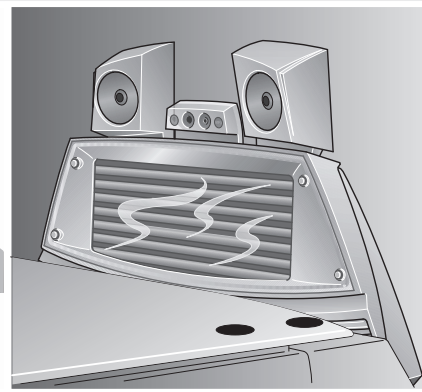

# OPERATING INSTRUCTIONS

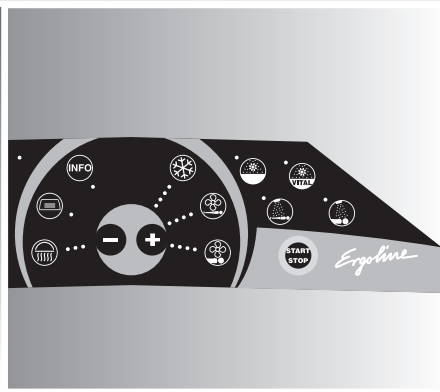
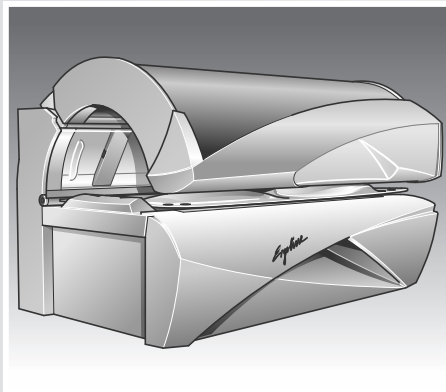

*Ergoline*

**AFFINITY 950**

**ULTRA POWER  
TEMPTRONIC**



USA

CDN

EXPOSURE  
12 min  
TIME

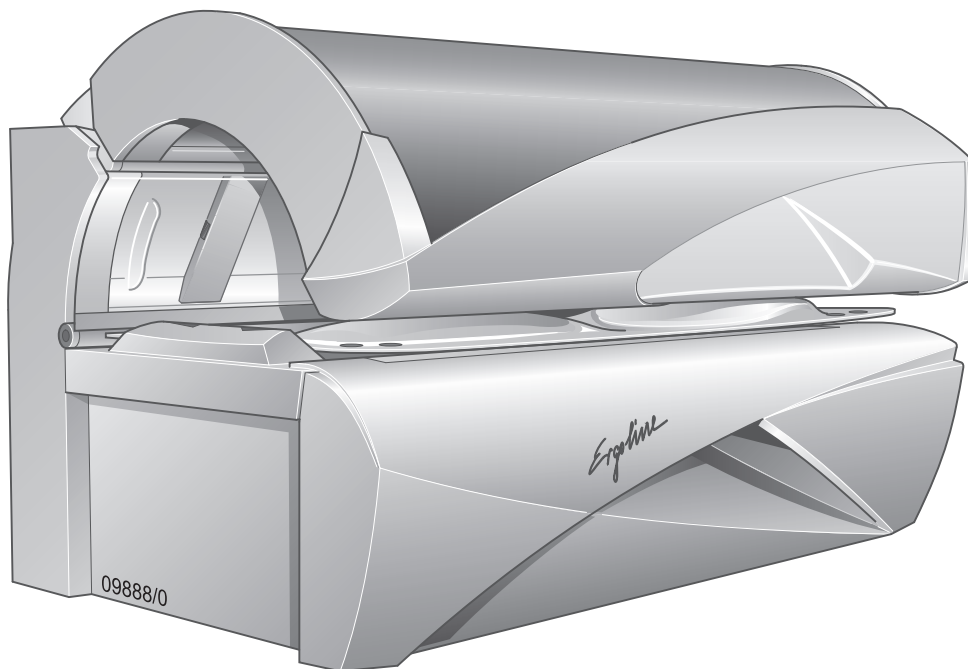

## Operating instructions

### AFFINITY 950 ULTRA POWER TEMPTRONIC

1003519-01 / us / 09.2012

*Ergoline*

## Contact information

**Technical Service JK Products & Services, Inc.**

#1 Walter Kratz Drive  
Jonesboro, AR 72401

Phone: 800-445-0624 (toll-free)

Fax: 870-935-9046

e-mail: [support@jkamerica.com](mailto:support@jkamerica.com)

<http://support.jkamerica.com>

### WARNING!



**Read these operating instructions.**

**Failure to observe these instructions:**

- may result in serious injury and death,
- can result in damage to the device and the environment.
- For the safety of yourself and others, read and observe all instructions contained herein before operating the tanning system.
- Please make the instructions and additional information available to anyone who operates or services the tanning system.

---

#### Copyright

The copyright remains with JK-Holding GmbH.

The contents may not be duplicated (in whole or part), distributed or utilized for competition purposes without authorization or disclosed to other parties.

The right to make technical changes in regard to the figures and information contained in this instruction manual is reserved!

## Table of contents

<b>1</b>	<b>Important information on tanning.....</b>	<b>6</b>
1.1	Skin types .....	6
1.2	Tanning times.....	6
<b>2</b>	<b>General.....</b>	<b>7</b>
2.1	Definitions .....	7
2.2	Identify your tanning device .....	7
<b>3</b>	<b>Safety notes.....</b>	<b>8</b>
3.1	Description of warning signs .....	8
3.2	Instructions pertaining to a risk of fire, electric shock, or injury .....	9
3.3	Instructions pertaining to a risk of damage to the machine .....	11
<b>4</b>	<b>Information for the studio operator .....</b>	<b>12</b>
4.1	Intended use .....	12
4.2	Foreseeable misuse.....	12
4.3	Obligations of the studio operator .....	12
4.4	Staff training .....	13
4.5	Guidelines .....	13
4.6	Installation location.....	13
4.6.1	Ventilation .....	13
4.7	Export.....	13
4.8	MP3 music (optional) .....	14
4.9	Disposal .....	14
4.9.1	Environmental regulations – disposal of lamps .....	14
4.10	Instruction signs on the device.....	14
4.11	Technical modifications.....	14
<b>5</b>	<b>Description .....</b>	<b>15</b>
5.1	Scope of delivery.....	15
5.1.1	Optional.....	15
5.2	Equipment.....	15
5.3	Device description .....	16
5.4	Accessories (optional).....	17
5.5	Function description .....	17

<b>6</b>	<b>Operation .....</b>	<b>18</b>
6.1	Mandatory reading .....	18
6.2	Use the tanning device – but use it properly! .....	19
6.3	Operation overview .....	20
6.4	Functions.....	21
6.5	Start.....	23
6.5.1	Preparation time .....	23
6.5.2	Interrupt or end tanning session .....	23
6.6	Connect MP3 player.....	24
<b>7</b>	<b>Cleaning and maintenance .....</b>	<b>25</b>
7.1	Safety instructions for cleaning and maintenance .....	25
7.2	Faults.....	26
7.3	Cleaning .....	27
7.3.1	Disinfection.....	27
7.3.2	Cleaning of surfaces.....	27
7.3.3	Filter panels and lamps .....	28
7.4	Cleaning plan .....	28
7.5	Maintenance.....	29
7.5.1	Acrylic panel.....	30
7.6	Maintenance plan .....	30
7.7	Cleaning and maintenance work preparation .....	33
7.7.1	Lift up the acrylic panel and the partition .....	33
7.7.2	Remove the canopy panel.....	34
7.7.3	Remove the side section panel .....	35
7.7.4	Open the bed base.....	36
7.8	Instructions for replacing the lamps.....	37
7.8.1	Low pressure lamps .....	37
7.8.2	Decor lighting sleeves .....	38
7.8.3	Starter.....	38
7.8.4	High pressure lamps and filter panels .....	39
7.9	Cleaning or replacing UV lamps in the base .....	40
7.10	Cleaning or replacing UV lamps and filter panels in the canopy.....	41
7.11	Cleaning or replacing UV lamps and filter panels in the side section.....	41
7.12	Cleaning or replacing UV lamps in the shoulder tanner .....	42
7.13	Cleaning or replacing the interior lighting .....	42
7.14	Cleaning or replacing the canopy accent lighting .....	44
7.15	Cleaning or replacing the front panel accent lighting.....	44
7.16	Cleaning or replacing Ambient Light (cabin lighting) .....	45
7.17	Cleaning the filters in the base .....	45
7.18	Cleaning the canopy filter mats .....	46
7.19	Cleaning the filter mats in shoulder tanner .....	47
7.20	Air conditioning/Temptronic: Empty the condensation tank and clean the filter .....	48

---

<b>8</b>	<b>Technical data .....</b>	<b>51</b>
8.1	Power rating, electrical specifications and noise level .....	51
8.2	Dimensions .....	52
8.3	Lamp configuration.....	53
8.3.1	AFFINITY 950 ULTRA POWER TEMPTRONIC .....	53
8.4	Accent lighting.....	54
8.5	Spare parts and accessories.....	55
<b>9</b>	<b>JK-Products, Inc. – Limited Warranty .....</b>	<b>56</b>
9.1	Limited Acrylic Warranty .....	57
9.2	Warranty Claims.....	57
9.2.1	Policy & Procedures.....	57
9.2.2	Labor Warranty Claim/Credit Procedures .....	58
9.3	Limited Lifetime Warranty .....	59
<b>10</b>	<b>Appendix.....</b>	<b>61</b>
10.1	Signs and stickers on the device.....	61
<b>11</b>	<b>Index.....</b>	<b>64</b>

# 1 Important information on tanning

## 1.1 Skin types

**Skin type I (Sensitive):**

Invariably gets sunburn, accepts little natural sunlight and does not tan.

**Skin type II (Fair):**

Gets sunburn easily and severely, tans minimally or lightly and peels.

**Skin type III (Average):**

Often referred to as "Average" complexion, gets moderate sunburns and tans about average.

**Skin type IV (Brown):**

Seldom gets sunburns, tans easily and above average with each exposure.

**Skin type V (Dark Brown):**

This individual's system rarely gets sunburns, tans easily and substantially.

## 1.2 Tanning times

This product is in conformity with performance standards for sunlamp products under 21 CFR 1040.

<p align="center"><b>DANGER ULTRAVIOLET RADIATION</b></p> <p>Follow instructions. Avoid over-exposure as with natural sunlight. Over-exposure can cause eye and skin injury and allergic reactions. Repeated exposure may cause premature aging of the skin and skin cancer.</p> <p><b>Maximum Tanning Time is 12 Minutes</b></p>	Recommended Exposure Schedule					
	Skin Type	Week 1 1st - 3rd Treatments	Week 2 4th - 6th Treatments	Week 3 7th - 10th Treatments	Week 4 11th - 15th Treatments	Weekly Subsequent Treatments
	I - Sensitive	NOT ADVISED	NOT ADVISED	NOT ADVISED	NOT ADVISED	NOT ADVISED
	II - Fair	2 Min.	5 Min.	8 Min.	10 Min.	12 Min.
	III - Average	2 Min.	5 Min.	8 Min.	10 Min.	12 Min.
	IV - Brown	2 Min.	7 Min.	10 Min.	12 Min.	12 Min.
V - Dark Brown	2 Min.	7 Min.	10 Min.	12 Min.	12 Min.	

<p><b>WEAR PROTECTIVE EYEWEAR! Failure to do so may result in severe burns or long term injury to the eyes.</b></p> <p>Certain medications or cosmetics may increase your sensitivity to the ultraviolet radiation. Consult a physician before using sunlamps if you are using medication, have a history of skin problems or believe yourself to be especially sensitive to sunlight. If you do not tan in the sun, you are unlikely to tan from the use of this product.</p>	<p>This unit utilizes UVA lamps. Replace only with Ergoline VHP 12 PREMIUM 160W Turbo Power, Ergoline VHP 25W Power (shoulder-/ neck-tanner) and Ergoline ultra 520W C12645 (high pressure) or recognized equivalents. To obtain recommended exposure at a minimum distance of 1/2" (13mm) measured with a standard ruler, lie on acrylic surface of lounge and lower canopy. Canopy will stop at the correct distance from lounge acrylic surface.</p> <p><b>Warning: The use of any other position may result in overexposure!</b></p>
--	--

<p>Tanning can begin on a regular basis. An appearance of tanning normally appears after a few exposures and maximizes after four (4) weeks of exposure following the recommended exposure schedule for skin type. In order to provide for maintenance of a tan a maximum of two (2) weekly 12 minute sessions is recommended from the fifth week onward.</p> <p><b>Do not tan more than once in a 24 hour period.</b></p>	<p>Use protective eyewear (Part No. Schmerler 2255 Red or recognized equivalents) when equipment is on. Read and follow instruction booklet before using this product. To avoid electrical shock during maintenance disconnect power from unit.</p> <p align="right">Part No: 801642a</p>
--	---



---

## 2 General

### 2.1 Definitions

---

**Operator**

People who provide tanning devices to users on a commercial basis. The operator is responsible for the orderly operation of the device as well as compliance with the maintenance intervals.

**User**

A person who uses the tanning device at a commercial location.

**Staff**

People who are responsible for the operation, cleaning as well as general maintenance work and who instruct the users in the operation of the devices.

**Electrician**

A person with suitable professional training, knowledge and experience which enables them to identify and avoid the dangers which can arise from working with electricity.

**Authorized, trained and qualified staff**

Qualified staff from an external company who have been trained and authorized by the manufacturer for assembly and maintenance work with specific tanning devices.

### 2.2 Identify your tanning device

---

For contact with Customer Services, please write down the device number of your tanning device, see page 61.

### 3 Safety notes

#### 3.1 Description of warning signs

---

Danger notices, damage to persons:

**DANGER!**

 **DANGER!** Type and source of danger, e.g. 'DANGER – High voltage!'  
Description of the consequences, e.g. 'You can be killed or injured by an electric shock!'  
Countermeasures:

- Disconnect device from power supply before opening.
- Do not reach into the inside with the device switched on.

---

Warning notices, damage to persons:

**WARNING!**

 **WARNING!** Type and source of danger, e.g. 'WARNING – hot surface!'  
Description of the consequences, e.g. 'You can burn your hand (skin, face)!'  
Countermeasures:

- Do not touch hot parts and nearby surfaces.
- Wait until hot parts and surfaces have cooled down.

---

Caution notices, damage to property:

**CAUTION!**

 The word 'Caution' with this label points out that danger for devices, materials and the environment can be expected here.

---

Important information:



**NOTE:**

This symbol does not identify safety notices, but states information for a better understanding of the processes.

## 3.2 Instructions pertaining to a risk of fire, electric shock, or injury

### DANGER – HIGH VOLTAGE!



**DANGER!**

#### You can be killed or injured by an electric shock!

Assembly and electrical connection must comply with national and local regulations.

- The device may only be assembled, installed, upgraded or repaired by specially trained and instructed personnel.

### WARNING!



**WARNING!**

#### Unprotected tanning may result in eye injury and eye diseases!

The unprotected eye can become inflamed on the surface, and in certain cases the retina can be damaged by excessive radiation. Cataracts can form after repeated exposure to radiation.

- **Inform users to use the included protective goggles that block UV.**

### WARNING!



**WARNING!**

#### Follow instructions!

Failure to use protective eyewear may result in severe burns or other eye injury. If discomfort develops, discontinue use and consult a physician.

- A person who does not tan in the sun most likely will not tan from the use of this device. Persons with very sensitive skins (skin type I) must not use the unit, as with this skin type tanning is impossible without damaging the skin (e.g. sunburn).
- Individuals with acute sunburn, individuals who have had or have skin cancer, or individuals who are at increased risk of skin cancer, must not use the system.
- Seek medical advice if you experience any unexpected effects, including itching, from using this UV device.
- The tanning device must never be used if a filter panel is missing or damaged, or the timer is defective!
- UV light from the sun or UV systems can cause injuries to the skin or eyes. This effect is dependent on the sensitivity of the individual's skin and on the type and amount of UV light.
- As with natural sunlight, overexposure can cause eye and skin injury, sunburn, and allergic reactions.
- Repeated exposure may cause premature aging of the skin and skin cancer.

- Medications (taken internally or otherwise) or cosmetics applied to the skin, may increase sensitivity to ultraviolet light.
  - A person having a history of skin problems should consult a physician before use.
- 

**WARNING!**



**Danger of long-term consequences!**

- Overexposure should be avoided.
  - Children may not use this device.
  - The following applies to minors under the age of 18 years: Only use tanning devices in agreement with a parent or guardian, or after consulting a physician. Check with your state regarding tanning laws for minors!
  - While there is no immediate clinical evidence of UV exposure and its effects upon expectant mothers, it is strongly advised that expectant mothers be discouraged from using the tanning unit.
- 

**WARNING!**



**Infections can be transferred through skin contact.**

All items/equipment components, with which the user can come into contact during tanning, must be disinfected after every tanning session:

- Protective goggles
  - Acrylic panel
  - Handles and control panel
  - MP3 cable
  - Adjustable air nozzles
  - Use only approved cleaners to disinfect the tanning system and its components.
-

**NOTE:**

Occasionally, persons using the tanning device will experience a slight reddening of the skin – usually in small patches – after the second or third session. This redness is often accompanied by an itching sensation. This may be nothing more than a very limited heat 'rash' caused by heat from the lamps within the device and it should go away within approximately 24 hours and not reappear. This rash can be lessened or prevented by applying moisturizing lotion to the affected area after the tanning session is completed.

- Follow instructions.
- The time between the first two tanning sessions must be at least 24 hours.
- Increasing tanning also requires an extension of the exposure time (= radiation time). After a certain degree of tanning has been achieved a further intensification is not possible. The session time may not be extended to exceed the scope of the permissible radiation doses! Only a certain degree of tanning, dependent on the skin type, can be achieved without endangering your health.
- Inform users about proper tanning.

### 3.3 Instructions pertaining to a risk of damage to the machine

**CAUTION!****Danger of overheating by obstruction of the air routing!**

- Do not change, obstruct or block the air inflow and outflow area to the device or make any unauthorized changes to the device. The manufacturer shall bear no liability for damage or injuries resulting from such actions.
- Before putting a tanning device into operation, the transport pallet must be removed from under the device. Danger of overheating by obstruction of the air routing.

## 4 Information for the studio operator

### 4.1 Intended use

---

The tanning device is intended exclusively for cosmetic tanning of the human skin.

- This device is used for tanning one adult person at a time.
- The user must wear suitable eye protection to block UV radiation during tanning.

Any other use shall be considered improper. The manufacturer cannot be held liable for damage or injuries resulting from misuse. The operator bears the sole risk for this.

The proper use also includes compliance with the manufacturer's instructions, operating and maintenance conditions. This device may only be operated, maintained and repaired by persons familiar with these tasks and who are aware of the dangers involved.

### 4.2 Foreseeable misuse

---

The following uses of the device are explicitly prohibited:

- Multiple people may not use the device at the same time.
- People with body weight of more than 300 lb (135 kg) may not use the device.
- Exceeding the specified tanning times may result in burns and long-term skin damage.
- When the device is in use no other people may remain in the room. This includes both children and adults.

### 4.3 Obligations of the studio operator

---

- As the operator you are responsible for informing users on possible risks of tanning.
- All danger and safety labels attached to the device must be observed! Do not remove them!
- No safety equipment (e.g. panel switch) may be removed, deactivated, or otherwise bypassed as it can impair the safe operation of the device!
- The device may only be used when in completely operational condition!
- It is the operator's responsibility to ensure the tanning system is handled properly.

## 4.4 Staff training

As the operator you are obligated to train your personnel and instruct them in the established legal and accident prevention regulations. Ensure that your staff have understood and observe these instructions. This includes:

- information regarding intended use and foreseeable misuse
- safety instructions
- operating instructions
- cleaning and maintenance instructions
- Please make the instructions and additional information from the manufacturer available to the staff at their workplace.
- Regularly check your staff's safety consciousness of the risks, taking into account your operating instructions.
- Please ensure that the cleaning intervals are complied with, in particular cleaning after every use.
- Please ensure that your staff provide your customers with appropriate advice, in particular regarding tanning times, possible risks and the operation of the device.

## 4.5 Guidelines

This product is in conformity with the performance standards for sunlamp products under 21 CFR 1040.20, FDA and listed with ETL and CAN/CSA 22.2 No. 224.

## 4.6 Installation location

### 4.6.1 Ventilation

#### CAUTION!



#### Danger of failure!

Danger of overheating by obstruction of the air routing.

- Observe the ventilation information to avoid serious system malfunctions.

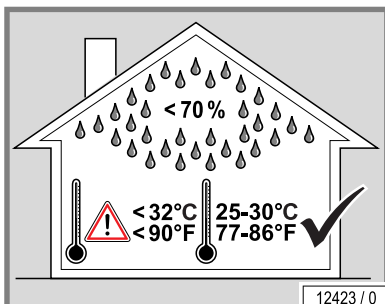

You can obtain data regarding the air supply and ventilation from the customer service department (see page 2).

## 4.7 Export

This device is exclusively intended for use in the USA and Canada and may not be exported to other countries and operated there! The manufacturer assumes no liability whatsoever in the event of non-compliance. High liability risks may occur for the exporter and/or the operator in the event of non-compliance.

## 4.8 MP3 music (optional)

---

The personal use of an MP3 player during tanning is not a public broadcast in copyright terms, so that there is no obligation for registration or payment by the studio owner to the corresponding copyright owning company. Copyright laws apply to the owner of the MP3 player.

The same regulations apply for the official use of MP3 music files as for other music sources: As studio owner you are only allowed to use original audio obtained from legal sources. Proof of the legitimacy of any MP3 audio used should be available for viewing upon demand of any regulatory body. Please refer to <http://www.riaa.com> for more information.



### NOTE:

Pre-recorded SD cards which are delivered as accessories for a JK audio system are also subject to payment obligation for commercial usage.

## 4.9 Disposal

---

### 4.9.1 Environmental regulations – disposal of lamps

UV low-pressure lamps and UV high-pressure lamps contain fluorescent materials and other waste containing mercury.

According to the national waste disposal laws and in accordance with the municipal waste regulations, proof must be provided of the proper disposal of UV lamps.

Contact your local environmental agency for assistance with the disposal of UV lamps.

## 4.10 Instruction signs on the device

---

See Appendix page 61.

## 4.11 Technical modifications

---

The device has been constructed in accordance with current safety regulations. The illustrations and specifications on these instructions are subject to technical modifications which are required in order to improve the device.

Unauthorized modifications and changes to the device and its control unit are prohibited.

Use only OEM spare parts.



---

## 5 Description

### 5.1 Scope of delivery

---

- Tanning device
- Lamps
- Air conditioning system
- Connecting lead
- Protective goggles
- Suction cup for filter panels
- Allen-key
- Technical documentation (folder with instructions, brochures for error codes and default settings and additional documentation)

#### 5.1.1 Optional

- Central exhaust air socket
- Audio system (with Voice Guide)
- Shoulder tanner
- Shoulder tanner with audio system (with Voice Guide)

### 5.2 Equipment

---

Device equipment varies depending on the model.

In this description, all standard and optional components/functions are taken into account which must be observed during operation and/or when performing maintenance.

The control panel also differs according to the varying equipment: Only those buttons that are visible can be operated, i.e. the corresponding function must be included in the device's equipment.

## 5.3 Device description

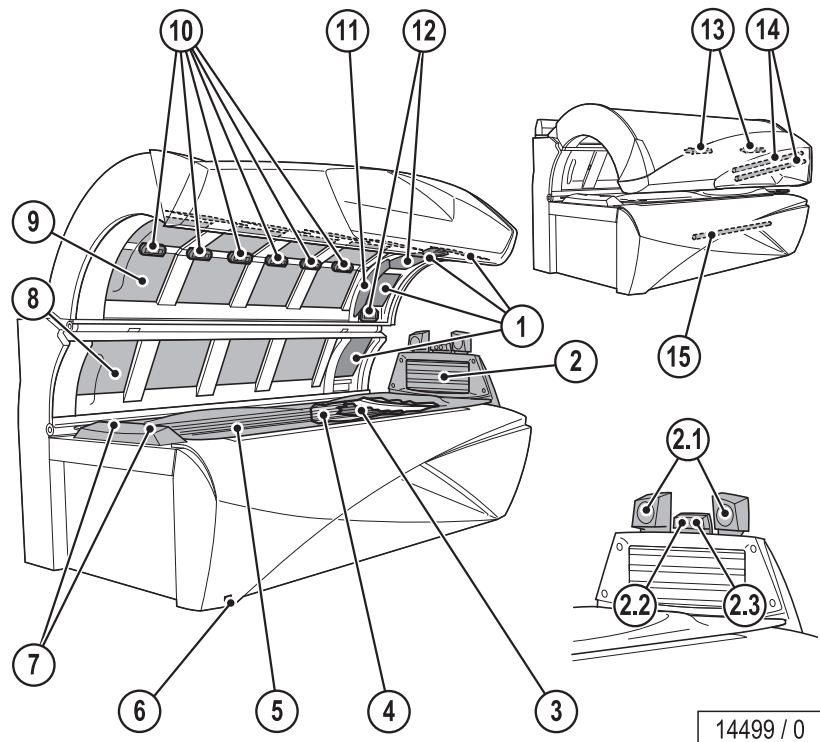

14499 / 0

1. Facial tanner (UV high pressure lamps)
2. Shoulder tanner with audio system (optional)  
loudspeaker (2.1), headphone connection (2.2), MP3-connection (2.3)
3. UV low pressure lamps, base
4. Partition
5. Acrylic panel base
6. Infrared interface
7. Body cooling air nozzles, foot end
8. UV high pressure lamps, side section
9. UV high pressure lamps, canopy
10. Body cooling air nozzles
11. Operating handle
12. Adjustable air nozzles – Facial cooling
13. Interior lighting
14. Accent lighting, canopy
15. Accent lighting, front panel

## 5.4 Accessories (optional)

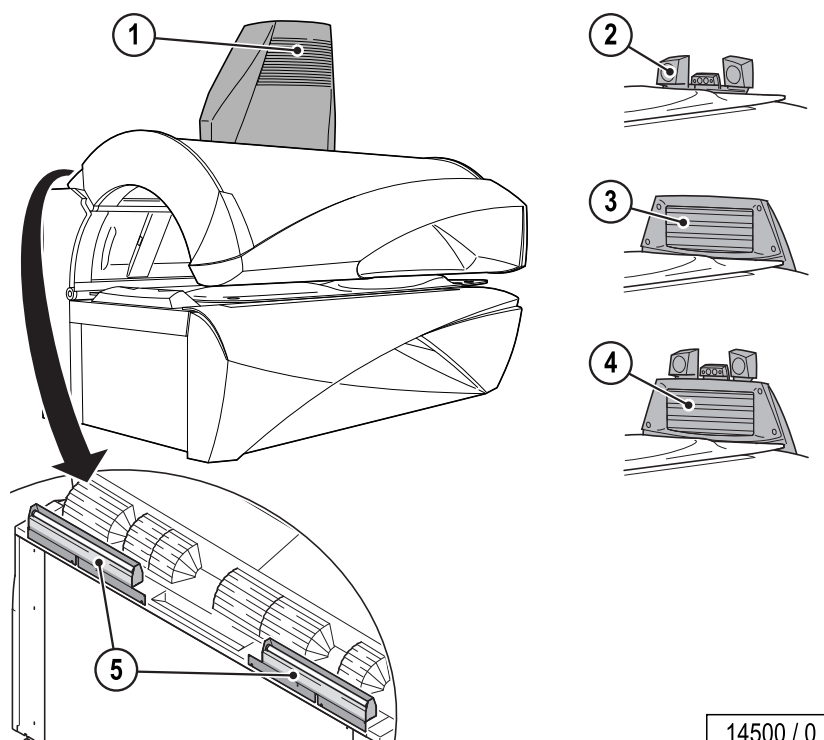

1. Central exhaust air socket
2. Audio system (with Voice Guide)
3. Shoulder tanner
4. Shoulder tanner with audio system (with Voice Guide)
5. Ambient Light (cabin lighting)

## 5.5 Function description

The primary technical components of a tanning device are an artificial source of UV radiation, a variety of filters and reflectors as well as a mechanical structure with a defined active surface.

Different tanning results can be achieved in varying strength tanning devices. This is due to the different strength UV lamps and the different UV-A and UV-B proportions of the UV radiation. The UV-A proportion primarily generates a superficial tan, which appears rapidly and is intensive but also fades more rapidly, the UV-B radiation is primarily responsible for more long-term tanning results. The disadvantage of the UV-B radiation is that the tan does not become visible until one or two days after visiting the tanning salon. Therefore, the appropriate tanning device is to be selected depending on the desired tanning goal.

The tanning devices described here primarily emit UV-A radiation.

## 6 Operation

### 6.1 Mandatory reading

---

Always read and follow all instructions for proper usage prior to allowing anyone to use the tanning device. The operating instructions included with this device must always be followed to prevent possible injuries.

Inform users

- to use provided UV-blocking protective eyewear whenever the equipment is energized.
- to follow the exposure schedule in accordance with their skin type. Failure to do so may result in overexposure.

A tanning system is not a toy. You cannot vary the strength of the lamps in your unit.

Should you have any questions regarding the proper use of your tanning system, contact Global Service USA at:

Phone: 800-445-0624 (toll-free)

Mon - Fri. 8:00 a.m. to 7:00 p.m. (CT)

Sat. 8:00 a.m. to 3:00 p.m. (CT)

#### WARNING!



**WARNING!**

#### **Danger of skin injuries and skin diseases.**

- The tanning device must never be used when a filter panel is missing or damaged, or the timer is defective!



#### **NOTE:**

When describing the operation, the tanning device is often shown with the canopy open. During tanning the canopy must always be closed.

Proper operation is not possible with the canopy open.

---

## 6.2 Use the tanning device – but use it properly!

---

A few things need to be noted to in order to obtain maximum enjoyment from a tanning device. Here are some answers to frequently asked questions.

### **Make-up in the tanning device?**

Please do not wear make-up. Clean skin absorbs UV light better.

A wide variety of materials is found in cosmetics. Whether these are emulsifiers, greases, or fragrances - in conjunction with UV radiation, these can cause skin allergy reactions.

Remove all make-up. This is essential. Make-up clogs the pores in the face. The UV light from a tanning device re-opens these clogged pores so that not only does the light penetrate the skin, but also the allergenic components of the make-up.

A further negative consequence of make-up is that the appearance of the skin deteriorates irreversibly over a period of time. However good make-up looks - in conjunction with UV light, it causes more harm than good. Therefore remove all make-up before a session in your tanning device - it will be much better applied afterwards.

### **Showering after leaving the tanning device?**

The browning is in the skin, not on it. Therefore you cannot wash it off. Treat your skin to a moisturizing cream after showering.

### **Are medications and the tanning device compatible?**

It is known that some medications increase the skin's sensitivity to UV light. This probability is particularly high with antibiotics, sulphonamides, psychiatric drugs, tranquillizers, anti-diabetes treatments and diuretics. Sun creams which contain psorale or kumarin also increase skin sensitivity. If you are in any doubt, first ask your doctor - then you can enjoy the sun at no risk.

### **Contact lenses in the tanning device?**

The answer is: Yes! Like any other tanning device user, contact lens wearers should also wear special protective goggles which protect the eyes against UV radiation. To guarantee better protection, wearers of glasses and contact lenses can ask their optician for exchange contact lenses with UV protection. The UV-A and UV-B filters built into exchange contact lenses will protect the cornea and the internal parts of the eye against almost 100 % of the energy in UV radiation.

This will benefit tanning device users not only in the open air, but on the tanning device itself. You can wear these contact lenses on the tanning device without any restrictions. For more information, ask your optician or optometrist.

### 6.3 Operation overview

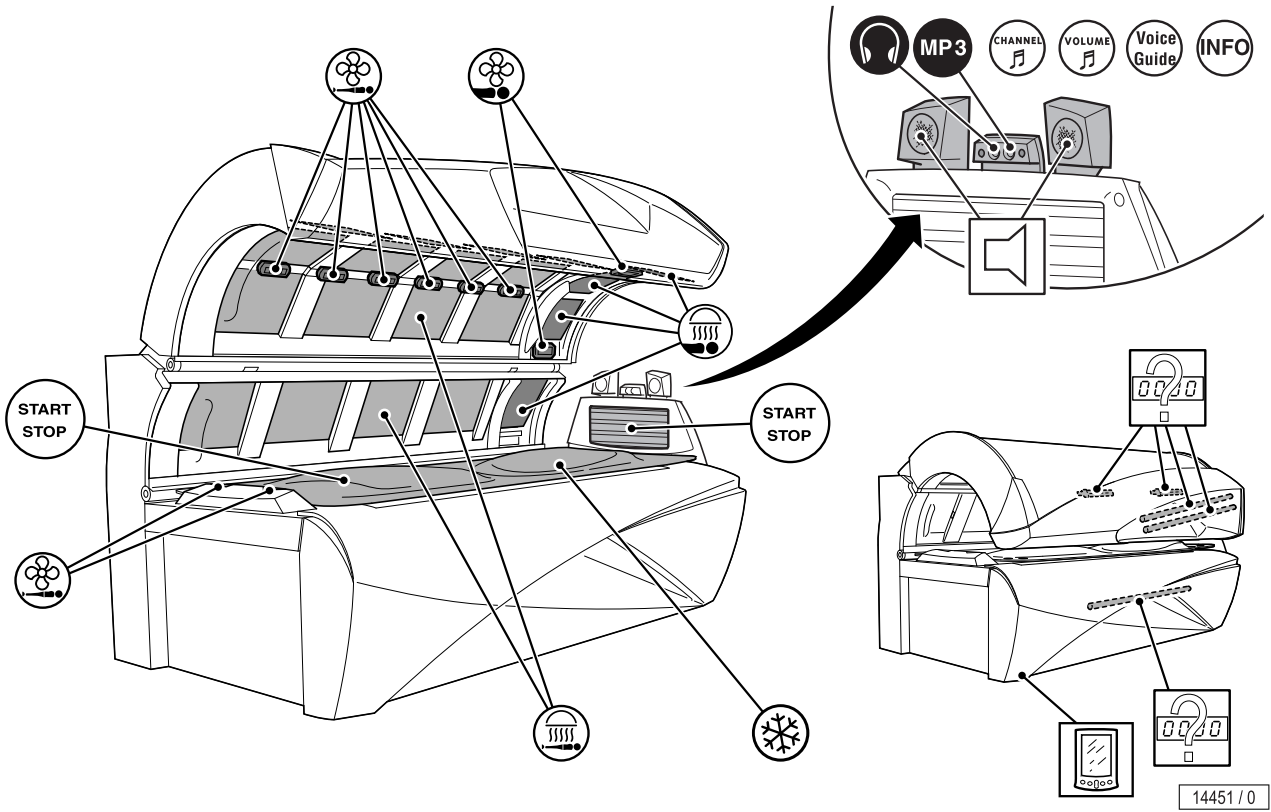

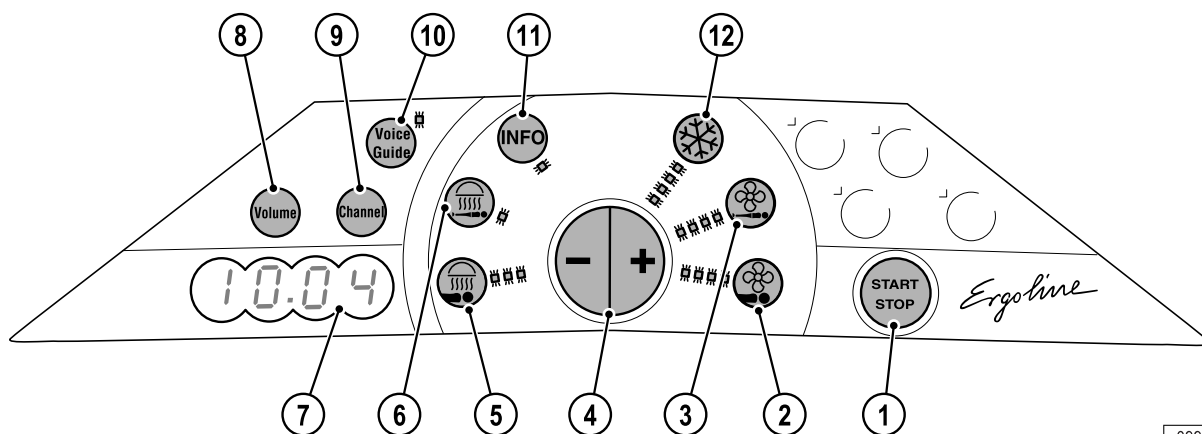

























09999 / 1

1. START/STOP button
2. Facial cooling button
3. Body cooling button
4. Plus/Minus button
5. Facial tanner button
6. Body tanner button
7. Display – Functions ...
8. Volume button
9. Audio system button
10. Voice Guide button
11. INFO button
12. Temptronic button

## 6.4 Functions

Function	Button sequence	Description	Information
1. UV lamps		START/STOP Switches the UV lamps on / off during the tanning session	The tanning time continues to run if the UV lamps are switched off during tanning session.
2. Facial cooling		Regulate facial cooling, levels 1-9	The face cooling air nozzles can be adjusted manually.
3. Body cooling		Regulate body cooling, levels 1-9	
5. Facial tanner		Regulating facial tanner, levels 1-3	
		Switching facial tanner off, press button for 2 seconds:	
		Switching facial tanner on	1 minute up until maximum power.
6. Body tanner		Regulating body tanner, levels 1-2	

Function	Button sequence	Description	Information
8. Volume	 	Adjusting the volume and switching-off the audio systems	
9. Audio system	 	I.CH (internal): SD card 'music'	
		Select title	
	 	E.CH (external): externally connected systems (e.g. CD-player)	
		Select channel	
	 	MP3 player	
10. Voice Guide	 	Switching Voice Guide off	Voice Guide provides an acoustic aid when running the unit and is only works in conjunction with audio system.  Voice Guide is switched on by default when getting ready for operation and during tanning.
	 	Switching Voice Guide on	
11. INFO		Switching INFO on	General information about the device.
		Select INFO text	
		Switching INFO off: Hold the button down	
12. Temptronic	 	Regulating the temperature, 65 °F - 85 °F (18 °C - 30 °C)	The acrylic panel will be cooled without adjustment control if the automatic air conditioning (Temptronic) fails. The user can only switch the cooling system (air conditioning) on or off in this case.
12. Air conditioning (Temptronic failure)	 	Switching air conditioning off, press button for 2 seconds: 	
	 	Switching air conditioning on	



## 6.5 Start

The device is started automatically with an internal or external timer.



### NOTE:

Timer instructions see separate manual (order no. 1008370-..).

### 6.5.1 Preparation time

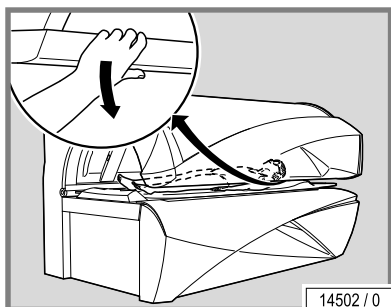

Before the UV lamps turn on, you have a few minutes to prepare yourself. During the preparation time you can switch on the UV lamps at any time by pressing the START/STOP button.

- Remove your clothes and all jewelry.
- Remove make-up and other cosmetics.
- Remove glasses. Contact lenses can be worn under the protective goggles.
- Put on the protective goggles.
- Lie down on the bed surface.
- Close the canopy.
- Press the START/STOP button.

Settings on start-up:

- UV lamps
- Facial tanner
- Body tanner
- Body cooling
- Facial cooling
- Temptronic
- Shoulder tanner (optional)
- Audio system (optional)
- Voice Guide (optional)

### 6.5.2 Interrupt or end tanning session

The tanning session ends automatically after the preset time has run down. The internal body cooling fan continues to run for approx. three (3) minutes to sufficiently cool the device.

- To interrupt a tanning session, press and hold button START/STOP any-time during a session.
- Press START/STOP again to restart the lamps.

## 6.6 Connect MP3 player

### DANGER!



**DANGER!**

#### Danger of hearing damage!

Using earphones or headphones at high volume can result in permanent hearing damage.

- Do not set the volume too high.

The user can connect their own private MP3 player to the tanning device, if the 'Audio system' accessory is fitted.

1. Jack plug (JK Part # 4630911001-..) provided for use by the studio operator (2 x 3.5 mm stereo jack plug).
2. MP3 player connection: see the documentation from the manufacturer of the MP3 player.

#### Connecting:

- Insert the MP3 cable (stereo jack plug) in the audio system.
- Plug the MP3 cable into the MP3 player.
- Select the music title and then start.
- Where necessary, set the volume level on the MP3 player so that the sound signal from the MP3 player is recognized by the audio system.

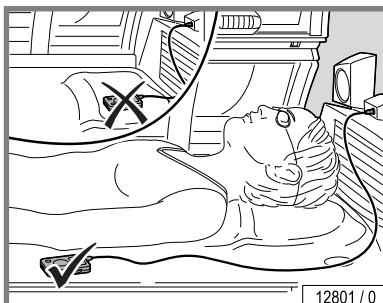
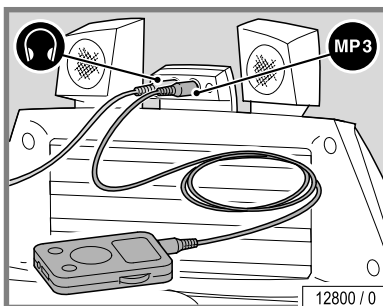
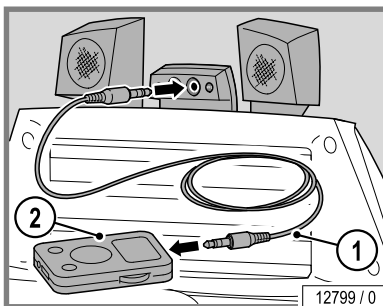

### CAUTION!



#### The heat might damage your MP3 player!

- Do not position the unit so that it receives direct tanning radiation.

### CAUTION!



#### Cable may be torn off, connectors may be damaged!

- Do not pull on cable when unplugging MP3 player.

## 7 Cleaning and maintenance

### 7.1 Safety instructions for cleaning and maintenance

#### DANGER – HIGH VOLTAGE!



**DANGER!**

#### You can be killed or injured by an electric shock!

During maintenance work there is a risk of touching live parts and receiving a fatal electric shock.

- Disconnect device from power supply before opening.
- Do not reach behind covers and do not open the device with the device switched on.
- Refit any safety devices (e.g. switches) after the work has been completed.

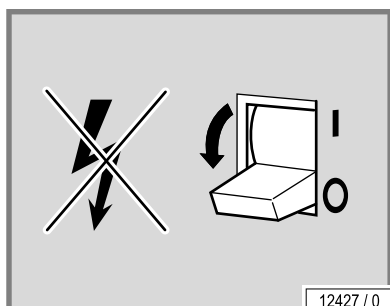

12427 / 0

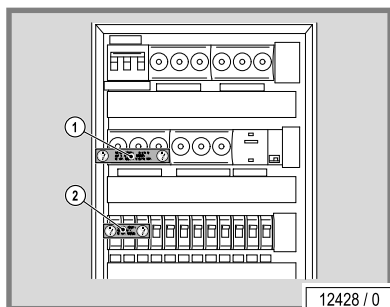

12428 / 0

If work is to be performed on the devices, they must be deenergized. That means that all live cables must be switched off.

Switching off the device alone is insufficient, as certain points may remain energized. Therefore, switch off fuses before performing any work and – if possible – remove them.

Accidental reactivation can result in serious accidents. Immediately after deenergizing, secure all switches or fuses used for deenergizing against being switched on again.

- Lock the fuse box with a padlock.

In case of circuit breakers which cannot be unscrewed, a strip of adhesive tape may be applied over the actuation lever with the wording 'Do not switch, danger!'.

A prohibition sign with the text:

'Work in progress!'

'Place: .....

'Sign may only be removed by: .....

must always be securely mounted immediately.

It is imperative that you, the owner and/or operator, check all components for any signs of wear which may occur through normal use.

- Observe the cleaning and maintenance schedule specified in the tables in Chapter 7.4 and 7.6.
- Only replace UV low-pressure lamps with the original type or compatible lamps.

Should you require any assistance or need additional information, please call Global Service USA at 800-445-0624 (toll-free), Monday through Friday 8:00 a.m. - 7:00 p.m. CT, Saturday 8:00 a.m. to 3:00 p.m.

**WARNING!**



**WARNING!**

**Injuries and damage due to improper maintenance!**

If the maintenance intervals for the UV lamps are exceeded or incompatible UV lamps are installed, the share of UVB radiation may increase. Sunburn and other skin damage may result.

Improper maintenance can cause the device to be damaged or to become unusable.

- Always comply with the specified maintenance intervals.
  - Follow the cleaning instructions.
- 

**WARNING!**



**WARNING!**

**Danger of burns from hot lamps and device parts!**

If the tanning device was operated before being switched off and opened, lamps and housing parts may be hot.

- Before replacing lamps or other spare parts, wait until lamps and metal parts of the device have cooled down sufficiently.
- 

**WARNING!**



**WARNING!**

**Danger of pinching!**

When opening and closing the panels and covers, you can pinch your fingers.

---

## 7.2 Faults

---

Error codes are output to the display to simplify troubleshooting:

- If a fault occurs, the error code flashes on the display.
- If several errors occur, the error messages are displayed alternately.
- Error elimination is acknowledged by pressing the **START/STOP** button.
- If the error cannot be cleared, contact Customer Service (see page 2) or your local service provider.

More detailed information regarding the error description and solutions is available in 'Error Codes' (order no. 1011831-..).

## 7.3 Cleaning

### WARNING!



**WARNING!**

#### Infections can be transferred through skin contact.

All items/equipment components, with which the user can come into contact during tanning, must be disinfected after every tanning session:

- Protective goggles
- Acrylic panel
- Handles and control panel
- MP3 cable
- Adjustable air nozzles
- Use only approved cleaners to disinfect the tanning system and its components.

### 7.3.1 Disinfection

For hygienic proper disinfection, use a specially developed disinfectant cleaner (such as Lucasol).



#### NOTE:

For thorough disinfection, the product must be allowed to remain in contact with the surface being disinfected for a specified amount of time. Follow the manufacturer's instructions for use.

### 7.3.2 Cleaning of surfaces

#### Acrylic panel

### CAUTION!



#### Do not rub with a dry cloth – danger of scratching!

- For hygienic proper cleaning of acrylic surfaces, use a specially developed disinfectant cleaner. Other cleaning agents, especially concentrated disinfectants or solvents (e.g. Lysoform, ethyl alcohol or other liquids containing alcohol) must never be used for cleaning.

**Failure to observe this voids all warranty claims.**

### CAUTION!



#### Acrylic panels unusable due to soiling!

Soiling on the panels is burned in by the hot lamps and results in the long term in unserviceable panels.

- Remove fingerprints and other soiling carefully.

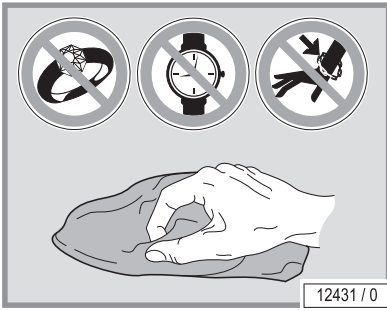

**Plastic surfaces**

For cleaning the remaining painted and unpainted plastic surfaces, it is best to use warm water and a cloth. Never use aggressive cleaning agents containing alcohol or essential oils. These may lead to damages not covered by the warranty.

During cleaning a slight discoloration of the cloth by the rubber seals should be expected for production-related reasons.

Prevent damage to the acrylic and plastic surfaces.

- Remove rings, watches, bracelets etc. before starting cleaning work.

**7.3.3 Filter panels and lamps**

- UV low pressure lamps and filter panels can be cleaned with a damp cloth (without additional cleaning agents) where necessary.
- UV high pressure lamps can be cleaned with ethyl alcohol where necessary.

**7.4 Cleaning plan**

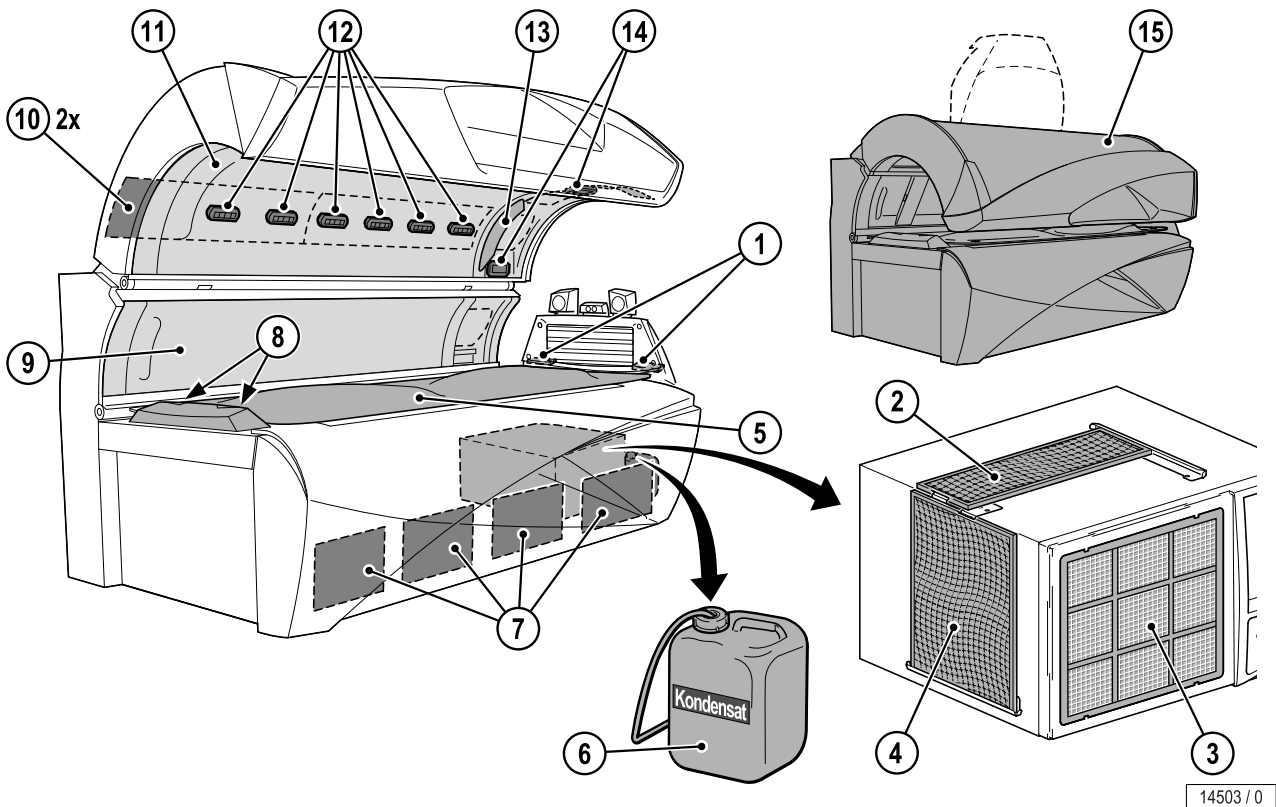

Component	Interval			Activity	See page
	After each tanning session	When necessary	50 h		
5	Acrylic glass panel	X		Cleaning and disinfection	27
13	Control panel	X		Cleaning and disinfection	27
14	Adjustable air nozzles	X		Cleaning and disinfection	27
	Handle	X		Cleaning and disinfection	27
	Protective goggles	X		Cleaning and disinfection	27
	MP3 cable	X		Cleaning and disinfection	27
6	Condensation tank		X	Empty	48
8	Body cooling air nozzles, foot end		X	Clean	27
9, 11, 15	Surfaces		X	Cleaning and disinfection	27
12	Body cooling air nozzles		X	Clean	27
1	Filter		X	Remove and clean filter	47
2-4	Filter		X	Remove and clean filter	48
7	Filter		X	Remove and clean filter	45
10	Filter		X	Remove and clean filter	46

**NOTE:**

If desired, you may set the unit to require that cleaning be confirmed after each tanning session by pressing the START/STOP button (when the cool-down time for the main fan has finished).

## 7.5 Maintenance

Maintenance and care play a major role in deciding the devices performance and appearance over its useful life. Diligent compliance at the specified intervals is absolutely necessary to ensure the proper operation of your tanning system.

The current operating hours of the parts requiring maintenance can be displayed in the Presetting mode – see separate instructions 'Presettings' (order no. 1011803-..).

Please note that the device must be inspected regularly by a JK authorized representative every 12 months (from date of installation) to maintain its proper condition!

### 7.5.1 Acrylic panel

**CAUTION!**



**Cosmetics may cause cracks to form on the surface!**

Over the long-term cosmetics or sunscreens cause damage (e.g. crack formation on the surface).

- Ensure that cosmetics and sunscreens are removed before tanning.

---

The acrylic panels for the tanning devices are produced of acrylic glass developed especially for this application. The acrylics used feature a particularly high UV permeability and resistance, as well as an easy-care, hygienic surface that is gentle on the skin.

The acrylic panels are formed to device-specific shapes in a technically complex production process. Despite state-of-the-art production know-how, the presence of minor spots, air bubbles or streaks in the acrylic panels is unavoidable. In addition, hairline cracks can occur on the acrylic panel during operation.

These occurrences are material-related and are unavoidable in processing. However, they have no significant effect on use and are therefore not accepted as defects.

Over the course of time the acrylic panel will become discolored as a result of usage and must be replaced by customer-service personnel on a regular basis.

The optional partition (only for devices with an air conditioning unit) works as a UV filter and must be replaced by customer-service personnel on a regular basis.

### 7.6 Maintenance plan

---

**CAUTION!**



Only use OEM spare parts of the same type! The use of other parts will void the manufacturer's warranty!

Any liability is excluded in case of damage or injury proven to be the result of the use of non-genuine spare parts.

---



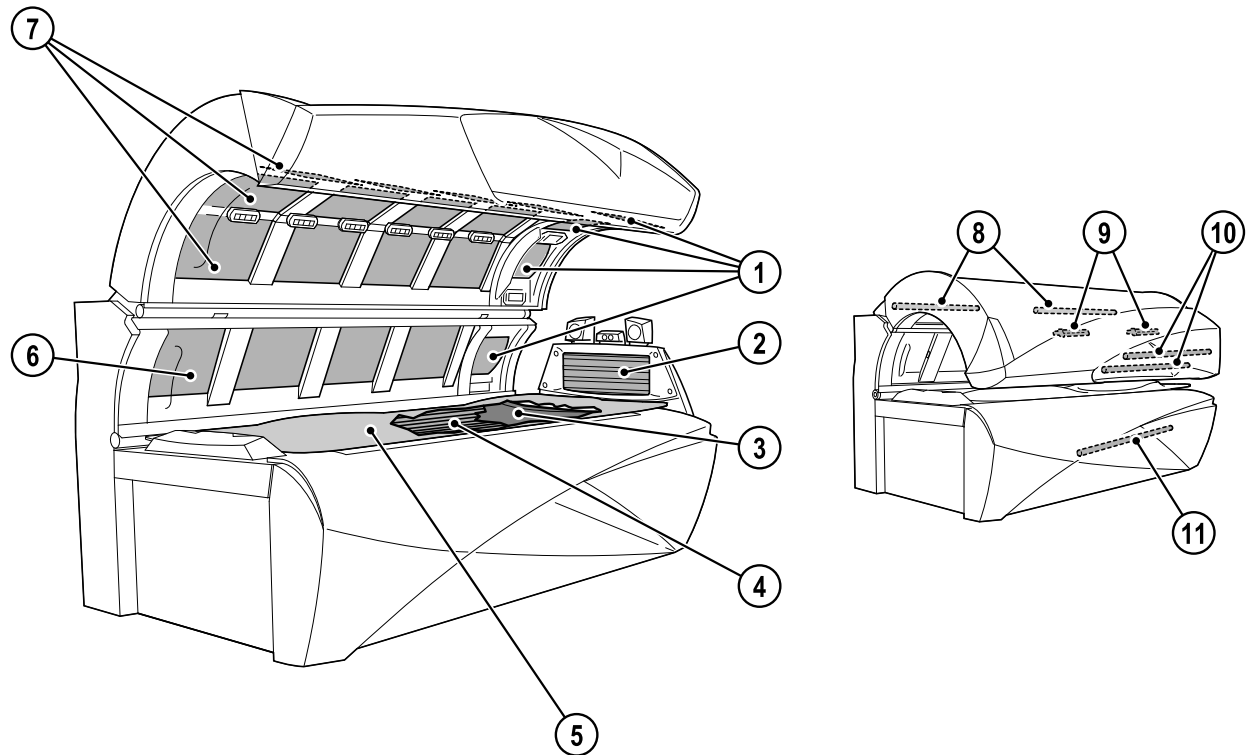

14504 / 0

Component	Interval					Activity	See page
	When necessary	500 h	1000 h	1500 h	3000 h		
9 Interior lighting	X					Replace	42
1 Facial tanner UV high pressure lamps		X				Replace	41
2 UV low pressure lamps, shoulder tanner		X				Replace	42
4 UV low pressure lamps, base		X				Replace	40
6 UV high pressure lamps, side section		X				Replace	41
7 UV high pressure lamps, canopy		X				Replace	41
2 Starter shoulder tanner			X			Replace	42
4 Starter base			X			Replace	40
8 Starter Ambient Light			X			Replace	45
10 Starter accent lighting, canopy			X			Replace	44
11 Starter accent lighting, front panel			X			Replace	44
5 Acrylic panel				X		Replace	30
3 Partition					X	Replace	30

In addition to the maintenance plan on page 31, the following items should be checked to ensure safe operation and use of your tanning system.

Component	Interval					Activity
	250 h / 3 months	500 h / 6 months	2500 h / 1 year	5000 h / 5 years	10000 h / 10 years	
1 Springs		X				Inspect and replace as necessary
Springs				X		Replace
2 Bolts and fasteners of the canopy hinge mechanism	X					Inspect and replace as necessary
Bolts and fasteners of the canopy lift mechanism	X					Inspect and replace as necessary
Bolts and fasteners of the canopy hinge/lift mechanism					X	Replace
3 Bolts and fasteners of the base/tank hinge/lift mechanism	X					Inspect and replace as necessary
Bolts and fasteners of the base/tank hinge/lift mechanism					X	Replace
4 Cylinders		X				Inspect and replace as necessary
Cylinders				X		Replace
5 Chassis and associated fasteners	X					Inspect and replace as necessary
Chassis and associated fasteners					X	Replace
6 Wiring and associated plugs / terminal connections	X					Inspect and replace as necessary
7 Acrylic panels		X				Inspect and replace as necessary
Acrylic panels			X			Replace
8 Acrylic support(s)			X			Inspect and replace as necessary
Acrylic support(s)				X		Replace
9 High pressure filter glass		X				Inspect and replace as necessary
High pressure filter glass			X			Replace

## 7.7 Cleaning and maintenance work preparation

### 7.7.1 Lift up the acrylic panel and the partition

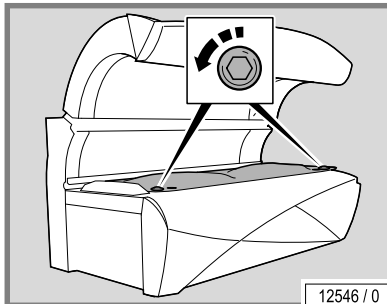

- Remove the screws.

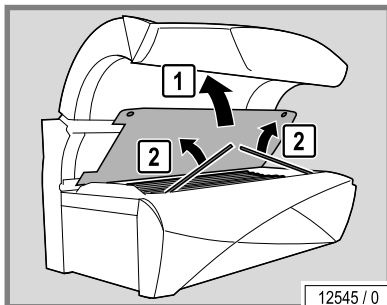

- Lift up the acrylic panel.
- Lift up the supports and prop the acrylic panel on them.

#### CAUTION!



#### Risk of scratching!

- Use the recesses provided on the acrylic panel.

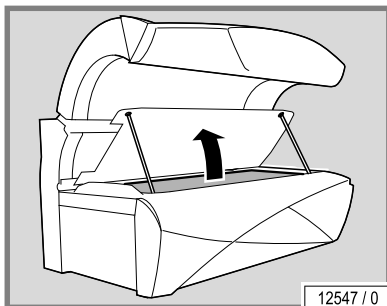

- Lift up the partition.

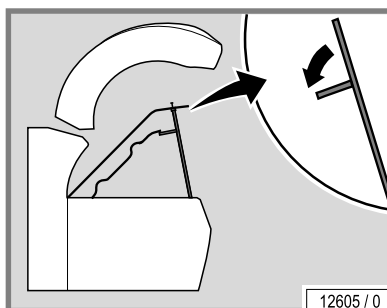

- Fold out the supports.
- Prop the partition on the supports.

The assembly is the same process in reverse order.

#### When assembling the device please note:

- Remove fingerprints and other soiling carefully.

### 7.7.2 Remove the canopy panel

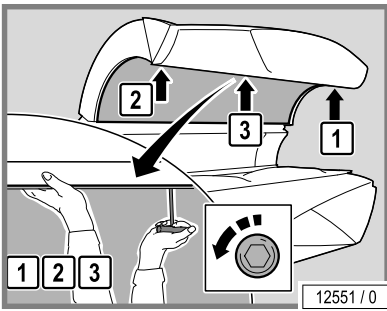

- Undo the screws. Remove the outside screws first and then remove the screw in the middle.
- Support the canopy panel with one hand so that it does not fall down.

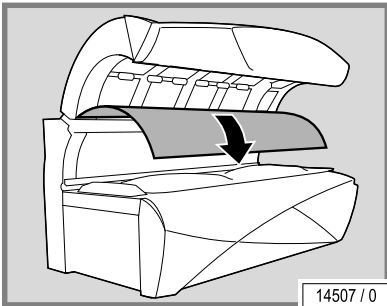

- Carefully lay the canopy panel aside.

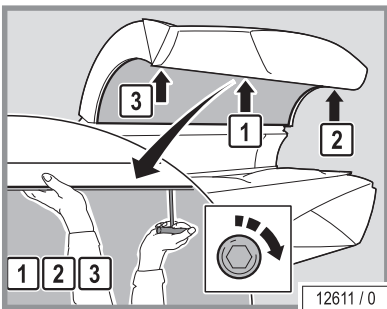

The assembly is the same process in reverse order.

**When assembling the device please note:**

- Support the canopy panel with one hand so that it does not fall down.
- Reinstall and retighten the screws. Reinstall the middle screw first and then the outer screws.
- Remove fingerprints and other soiling carefully.

### 7.7.3 Remove the side section panel

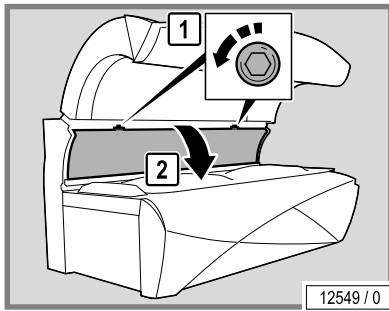

- Remove the screws.

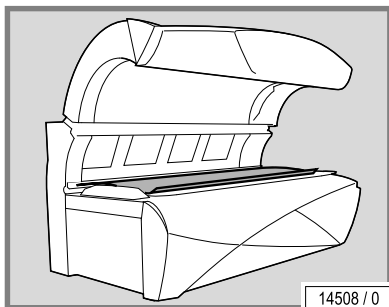

- Open the panel and lay it down carefully.

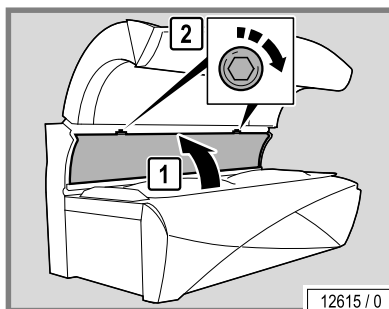

The assembly is the same process in reverse order.

**When assembling the device please note:**

- Remove fingerprints and other soiling carefully.

### 7.7.4 Open the bed base

- Remove the screws.

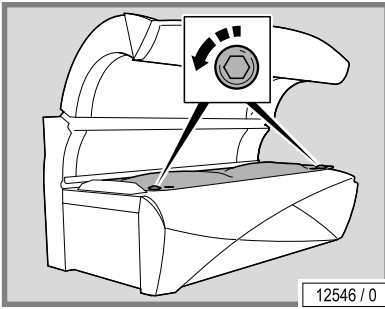

- From the front reach into the front panel and unlock the lock.
- Lift up the bed base.

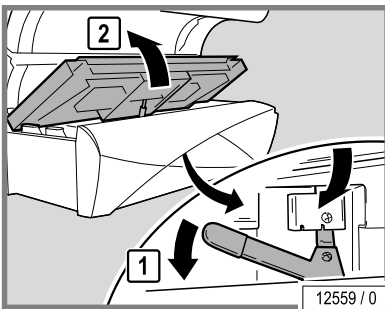

The assembly is the same process in reverse order.

**When assembling the device please note:**

- The bed base must lock with an audible click when closed.

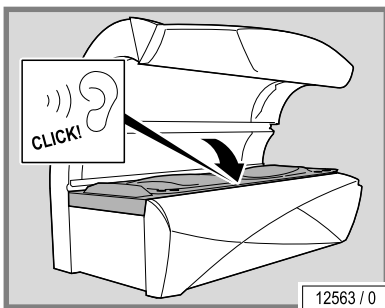

## 7.8 Instructions for replacing the lamps

The lamp's UV effect and therefore the tanning effect decrease over time. You must adhere to the replacement intervals specified in the maintenance plan.

UV filters are used in order to control the UV radiation, e.g. the filter panels in the facial tanner. However, the filter effect decreases over the course of time. You must adhere to the replacement intervals specified in the maintenance plan.

### 7.8.1 Low pressure lamps

- Replace faulty UV low pressure lamps immediately. Install replacement lamps to the outer edges of the tanning area.
- Always replace the entire set of lamps after the specified operating time.
- Turn 90° and carefully remove from the socket.

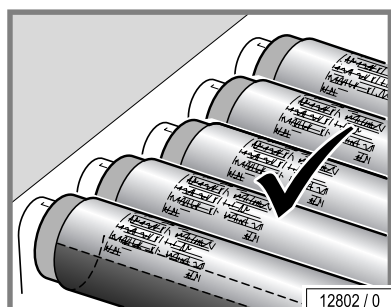
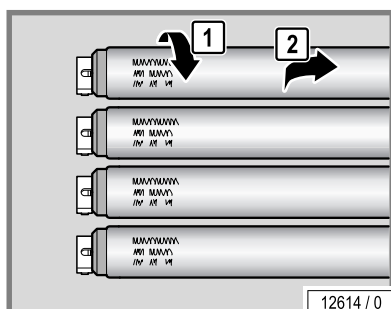

- UV low pressure lamps possess a reflector which directs the light outwards. The lamps must be mounted in such a way that the rear side of the reflector is located on the device side.

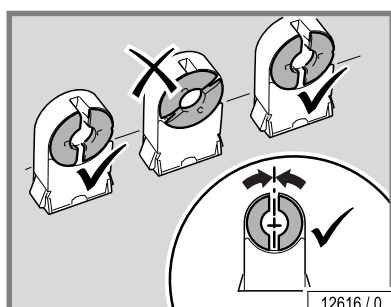

- Push the pins vertically into the socket from above.

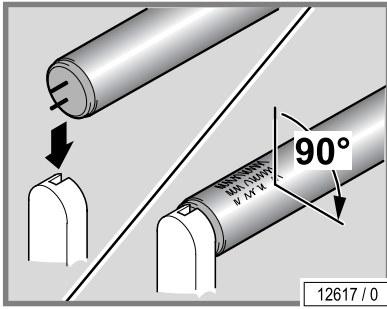

- Turn the lamp 90°. The lettering must be oriented towards the outside (i.e. towards the tanning room or towards the user).

### 7.8.2 Decor lighting sleeves

Colored sleeves can be fitted on the accent lamps. The sleeves do not have to be changed, merely refitted with the new lamps.

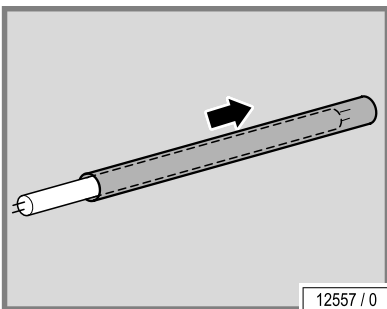

- Remove the sleeve from the old lamp.

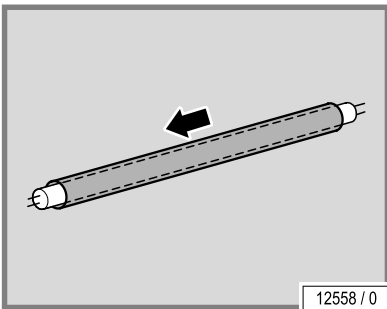

- Slide the sleeve onto the new lamp.

### 7.8.3 Starter

- Replace faulty starters immediately.

You can recognize a faulty starter by the blackened ends of the lamps or when the lamps can no longer be started.

Operating a lamp with a faulty starter significantly shortens its service life. The lamp loses power and may begin to flicker under certain circumstances.

The starters are located in either one of the two lamp sockets or are visible when the lamps are removed.

- Turn 90° and carefully remove from the socket.

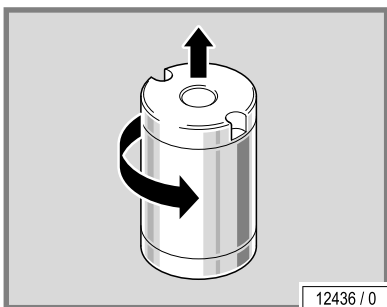



## 7.8.4 High pressure lamps and filter panels

UV high pressure lamps are used in the facial tanner and body tanner (in the canopy and side section).

### WARNING!



**WARNING!**

#### Fire hazard due to overheated lamps!

Non-approved high pressure lamps can explode. Hot lamp components can set other parts on fire. People can be killed or severely injured due to smoke inhalation and fire.

- Only fit the high pressure lamps specified by the manufacturer.
- Clean the inside of the device regularly. Dust particles are flammable!

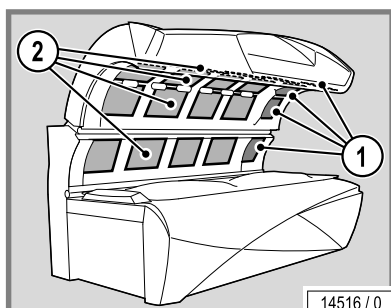

### CAUTION!



#### Do not interchange filter panels!

The facial tanner and the body tanner are equipped with different filter panels.

- Facial tanner (1):  
Ultra Performance 411, order no. 1001068-..
- Body tanner (2):  
Ultra 611, order no. 1003259-..

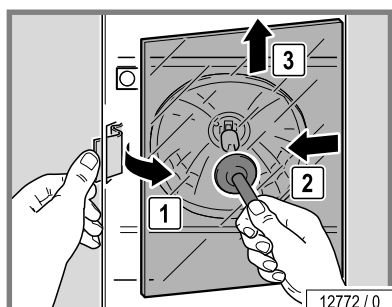

- Release the clamping holder.
- Lift the filter panel, pull it out of the guide and remove it.



- Unplug the UV lamps.
- Clean the reflector.

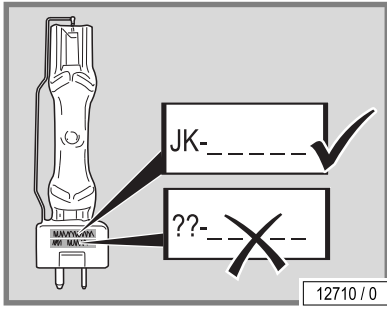

- Only utilize original UV lamps.

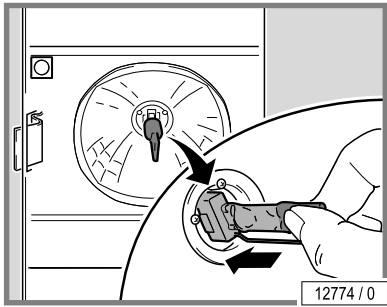

- Only touch new lamps in the handling zone.

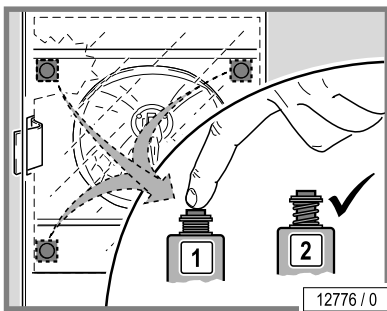

- Test the safety switch to ensure that it works.  
The safety switch ensures that the device switches off in the event of a faulty filter panel or when a filter panel is missing.
- Press the button.  
If the button springs back automatically then it is functional.
- Replace the filter panel.

## 7.9 Cleaning or replacing UV lamps in the base

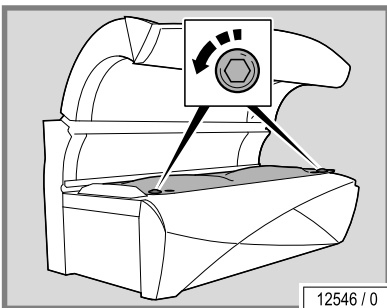

- Lift up the acrylic panel and the partition: see page 33.

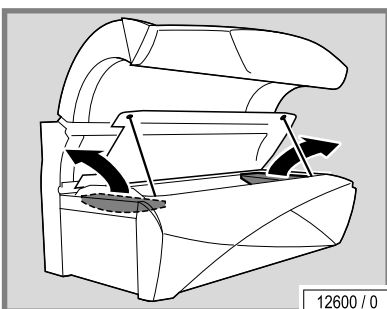

- Remove the lamp covers at the head and foot ends.  
Replacing UV low pressure lamps: see page 37.  
Replacing starters: see page 38.

The assembly is the same process in reverse order.

## 7.10 Cleaning or replacing UV lamps and filter panels in the canopy

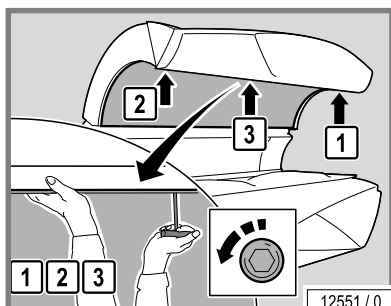

– Removing the canopy panel: see page 34.

Replacing UV high pressure lamps and filter panels: see page 39.

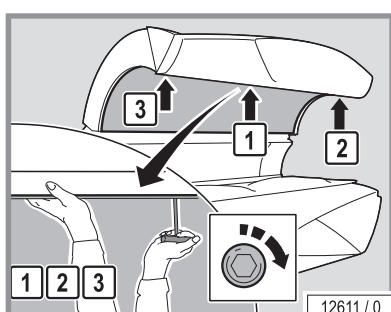

The assembly is the same process in reverse order.

**When assembling the device please note:**

- Support the canopy panel with one hand so that it does not fall down.
- Refit and retighten the screws. Refit the middle screw first and then the outer screws.

## 7.11 Cleaning or replacing UV lamps and filter panels in the side section

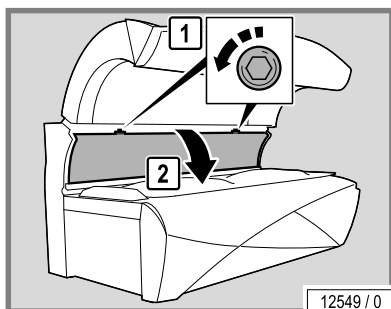

– Removing the side section panel: see page 35.

Replacing UV high pressure lamps and filter panels: see page 39.

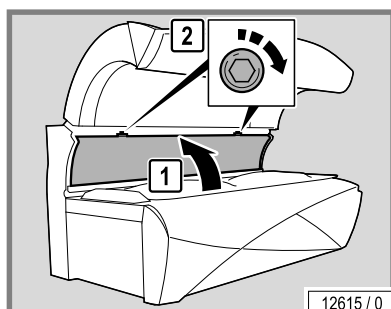

The assembly is the same process in reverse order.

## 7.12 Cleaning or replacing UV lamps in the shoulder tanner

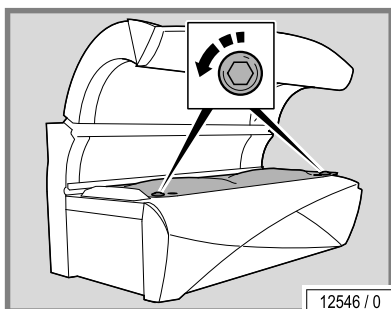

- Opening the bed base: see page 36.

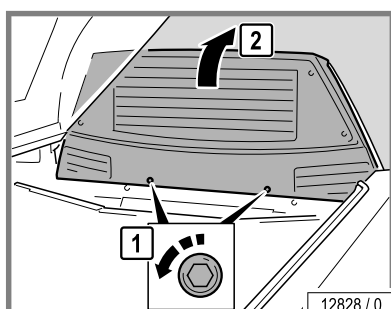

- Remove the screws and then remove the lamp cover.

Replacing UV low pressure lamps: see page 37.

Replacing starters: see page 38.

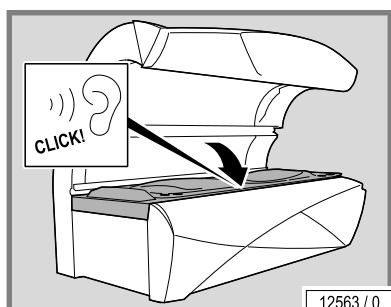

The assembly is the same process in reverse order.

**When assembling the device please note:**

- The bed base must lock with an audible click when closed.

## 7.13 Cleaning or replacing the interior lighting

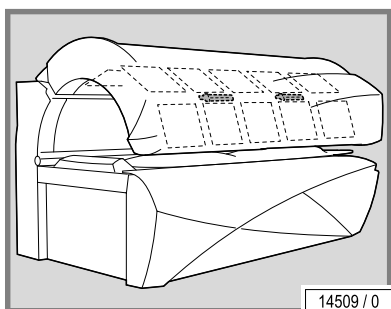

Two (2) interior lights are located between the UV high pressure lamps.

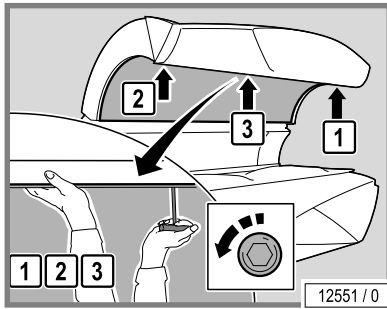

- Removing the canopy panel: see page 34.

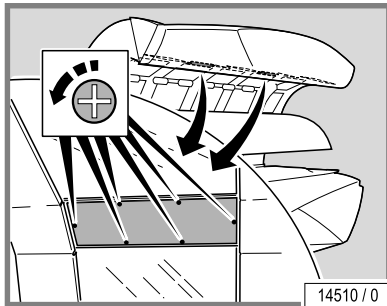

- Remove the screws.

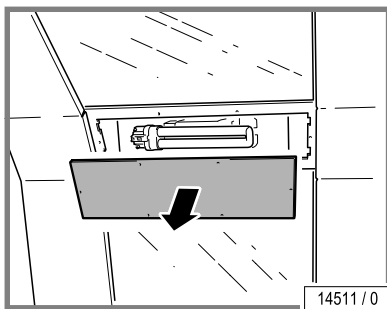

- Remove the cover.

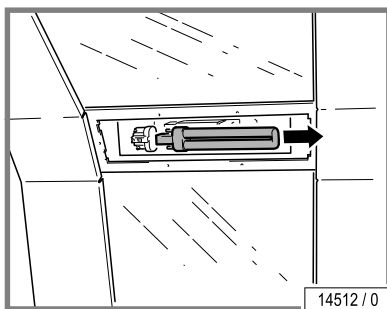

- Pull out the lamp.

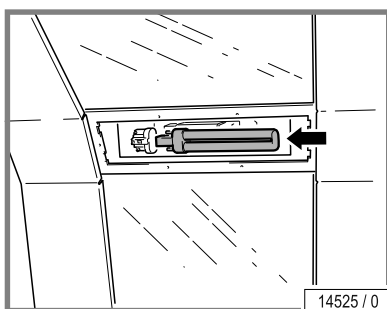

- Insert the new lamp.

The assembly is the same process in reverse order.

## 7.14 Cleaning or replacing the canopy accent lighting

Two (2) accent lights are located in the canopy.

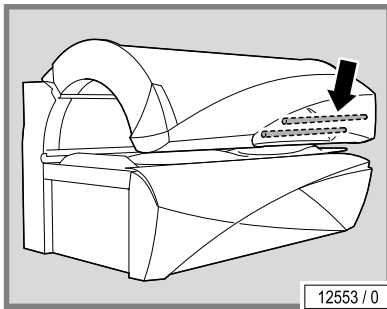

12553 / 0

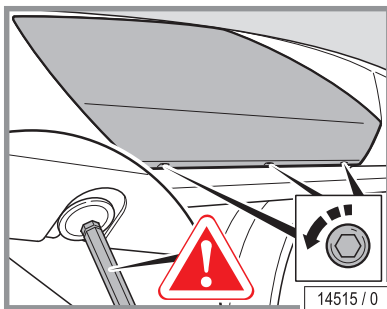

14515 / 0

### CAUTION!



**May damage paintwork!**

- Keep away from lower edge when fitting.

- Remove the screws.
- Remove the cover.

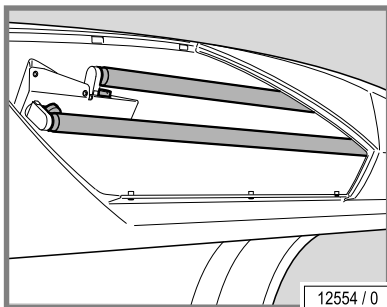

12554 / 0

Replacing lamps: see page 37.

Replacing starters: see page 38.

Decor lighting sleeves (if fitted): see page 38.

The assembly is the same process in reverse order.

## 7.15 Cleaning or replacing the front panel accent lighting

- From the front reach under the front panel and remove the accent light.

Replacing lamps: see page 37.

Replacing starters: see page 38.

Decor lighting sleeves (if fitted): see page 38.

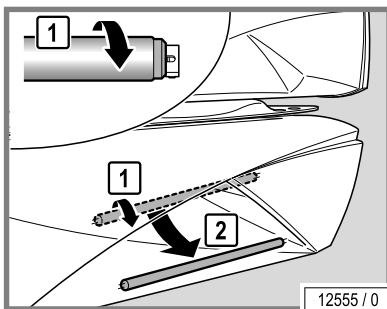

12555 / 0

The assembly is the same process in reverse order.

## 7.16 Cleaning or replacing Ambient Light (cabin lighting)

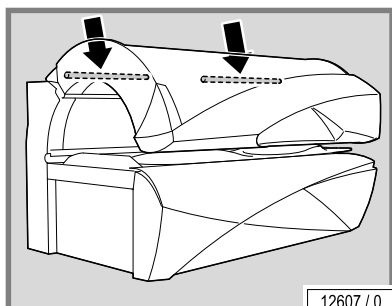

12607 / 0

Two (2) accent lights are located on the rear side of the canopy.

- If necessary, cover the canopy in order to prevent the paint from being scratched.
- Remove the lamps on the rear of the canopy.

Replacing lamps: see page 37.

Replacing starters: see page 38.

Decor lighting sleeves (if fitted): see page 38.

The assembly is the same process in reverse order.

## 7.17 Cleaning the filters in the base

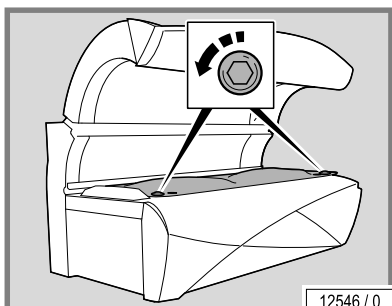

12546 / 0

- Opening the bed base: see page 36.

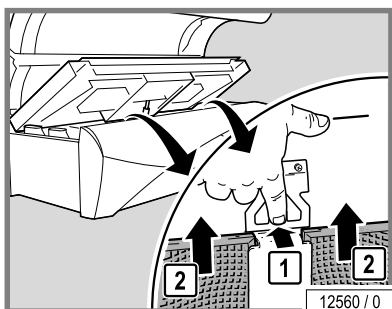

12560 / 0

- Remove the filters.

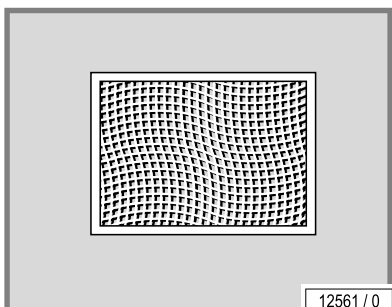

12561 / 0

- Cleaning the filters when wet or dry.

Dry cleaning: Vacuum cleaner (depending on the degree of soiling)

Wet cleaning: Use water and detergent or put in a dish-washer

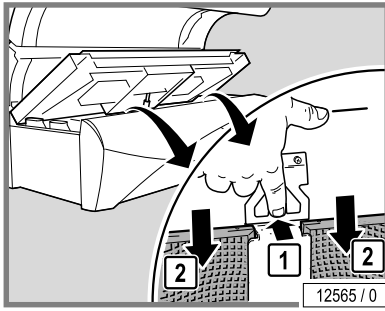

**CAUTION!**



**The device may be damaged by moisture!**  
The cleaned filters must be dry before they are replaced.

- Reinstall the cleaned and dried filters.
- Close the bed base. You should hear the bed base click into place.

## 7.18 Cleaning the canopy filter mats

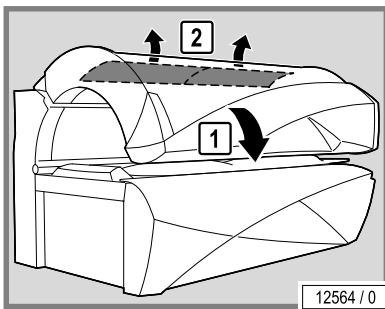

- If necessary, cover the canopy in order to prevent the paint from being scratched.
- Remove the filter mats fitted at the back of the canopy.

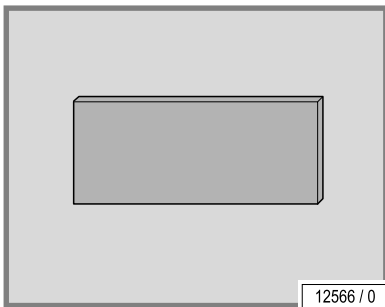

- Dry or moist clean the filter mats or replace with new ones.  
Dry cleaning: Vacuum cleaner (depending on the degree of soiling)  
Moist cleaning: Water and detergent
- **Do not clean in the dish-washer!**

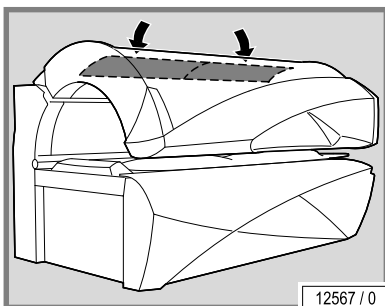

**CAUTION!**



**The device may be damaged by moisture!**  
The cleaned filters must be dry before they are replaced.

- Reinstall the cleaned and dried filter mats.



## 7.19 Cleaning the filter mats in shoulder tanner

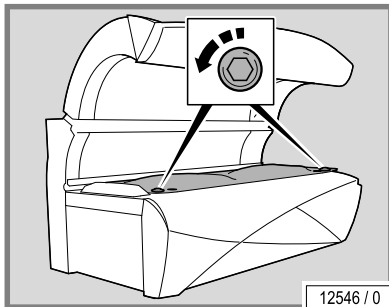

- Opening the bed base: see page 36.

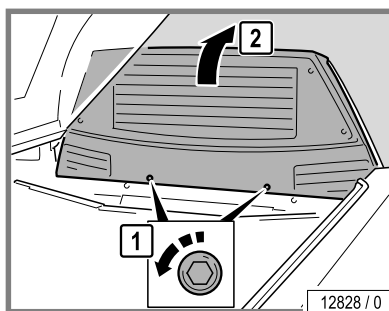

- Remove the screws and then remove the lamp cover.

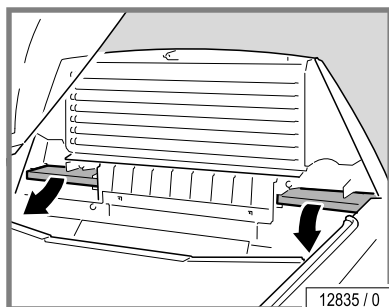

- Remove the filter mats.

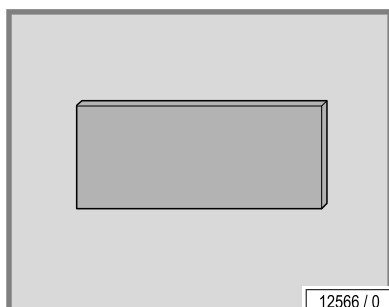

- Dry or moist clean the filter mats or replace with new ones.

Dry cleaning: Vacuum cleaner (depending on the degree of soiling)  
Moist cleaning: Water and detergent

- **Do not clean in the dish-washer!**

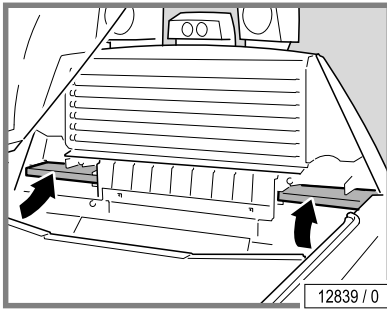

**CAUTION!**

**The device may be damaged by moisture!**

The cleaned filters must be dry before they are replaced.

- Refit the cleaned and dried filter mats.

The assembly is the same process in reverse order.

**When assembling please note:**

- The bed base must lock with an audible click when closed.

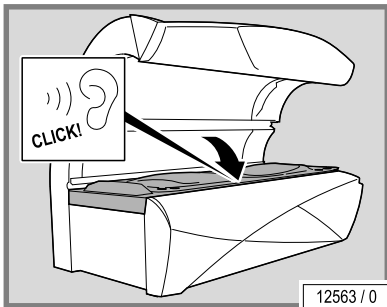

## 7.20 Air conditioning/Temptronic: Empty the condensation tank and clean the filter

**CAUTION!**



**Damage to the device through soiled filters and cooling fins!**

Regularly check the filter grill and cooling fins on the air conditioning system and clean if necessary.

We recommend using the specially manufactured fin comb, art-no. 15720470, to clean the cooling fins.

- Opening the bed base: see page 36.

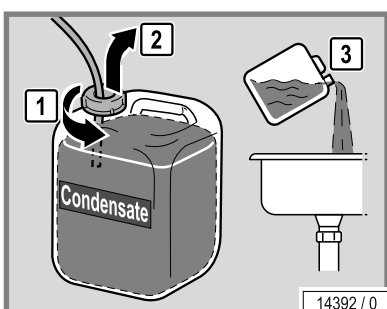
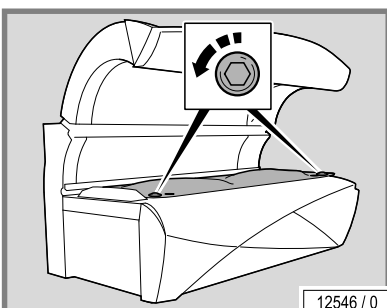

- Bring the condensation tank forwards.
- Disconnect the hose on the condensation tank.
- Empty the condensation tank.

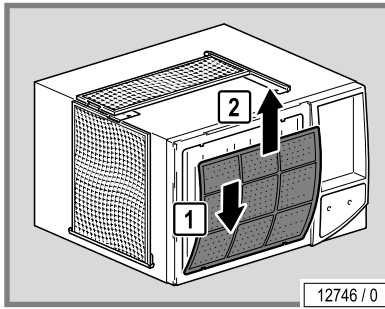

- Remove the filter from the holder.

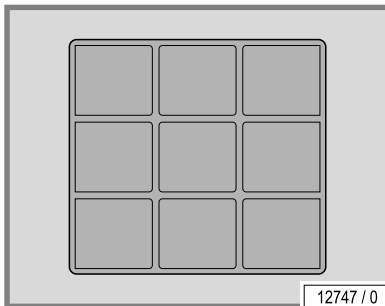

- Cleaning the filter when moist or dry.  
 Dry cleaning: Vacuum cleaner (depending on the degree of soiling)  
 Moist cleaning: Water and detergent
- **Do not clean in the dish-washer!**

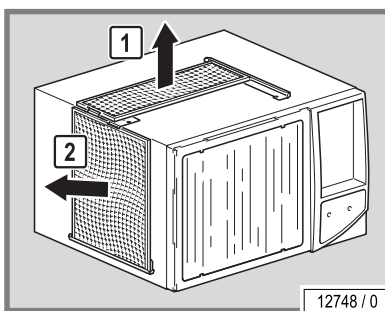

- Remove the filters from the holder.

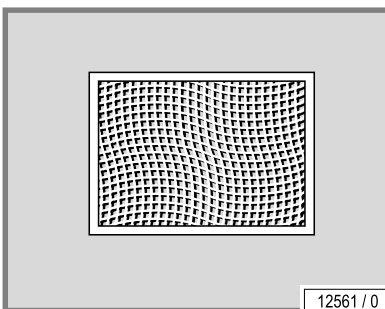

- Cleaning the filters when wet or dry.  
 Dry cleaning: Vacuum cleaner (depending on the degree of soiling)  
 Wet cleaning: Use water and detergent or put in a dish-washer

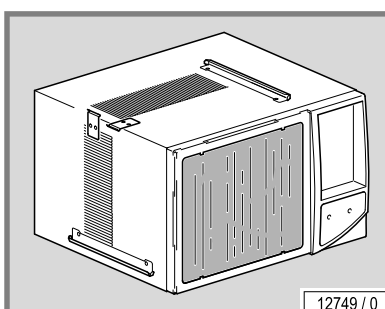

- Use a fin comb to clean the air conditioning's dirty cooling fins.



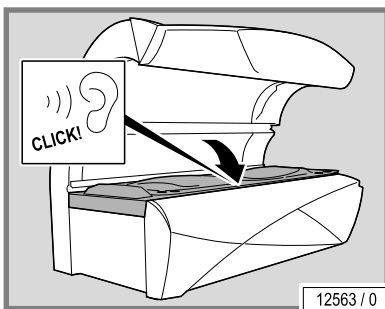
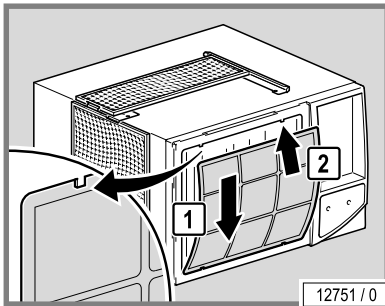
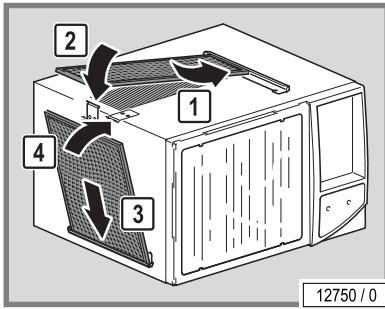

**CAUTION!**



**The device may be damaged by moisture!**

The cleaned filters must be dry before they are replaced.

- Reinstall the cleaned and dried filters.
- Ensure that the filters are correctly positioned in the holder.

- Connect the condensation tank to the hose.
- Refit the condensation tank.
- Close the bed base. You should hear the bed base click into place.

## 8 Technical data

### 8.1 Power rating, electrical specifications and noise level

#### AFFINITY 950 ULTRA POWER TEMPTRONIC

Nominal power consumption:	21,000 W
Rated frequency:	60 Hz
Rated voltage:	230 V
Rated fuses:	90 amp 3-pole
Noise level at 1 m distance from the device (without exhaust air):	68.9 dB(A)
Noise level in device:	<81 dB(A)
Load on the acrylic panel:	max. 300 lb / 135 kg
Weight:	approx. 1,642 lb / 745 kg

## 8.2 Dimensions

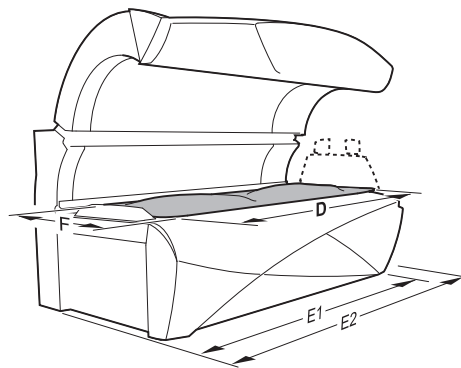
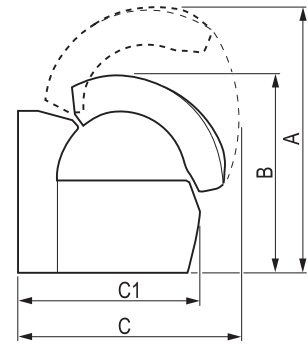
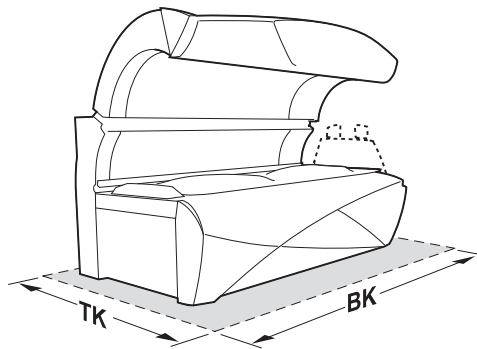

12845 / 0

A =	73 1/4 in	1,860 mm
B =	53 9/16 in	1,360 mm
C =	62 in	1,575 mm
C1 =	55 7/8 in	1,420 mm
D =	78 3/4 in	2,000 mm
E1 =	89 in	2,260 mm
E2 =	92 1/2 in	2,350 mm
F =	35 7/16 in	900 mm
TK =	90 9/16 in	2,300 mm
BK =	94 1/2 in	2,400 mm

## 8.3 Lamp configuration

### CAUTION!



The use of other UV lamps and filter panels voids the operating license!

### 8.3.1 AFFINITY 950 ULTRA POWER TEMPTRONIC

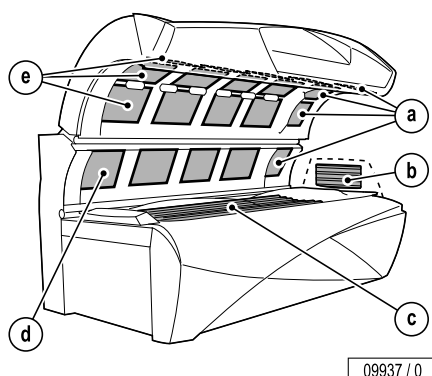

#### Installed lamps

	Number	Description	Length	Power	Control	Order no.
a)	4	UV high pressure lamps Ergoline ULTRA C12645		520 W	420 W / 360 W / 260 W / 0 W	12645-..
	4	Filter panels Ultra Performance 411				1001068-..
b)	7	UV low pressure lamps Ergoline VHP™ 25 W Power	21 in 0.52 m	25 W	25 W	12562-..
	7	Starter S10 (4-65 W)				10047-..
c)	19	UV low pressure lamps Ergoline VHP™ 12 160 W TURBO POWER PREMIUM	71 in 1.80 m	160 W	160 W	12788-..
	19	Starter (120-180 W)				12637-..
d)	4	UV high pressure lamps Ergoline ULTRA C12645		520 W	420 W / 360 W / 260 W / 0 W	12645-..
	4	Filter panels Ultra 611				1003259-..
e)	12	UV high pressure lamps Ergoline ULTRA C12645		520 W	420 W / 360 W / 260 W / 0 W	12645-..
	12	Filter panels Ultra 611				1003259-..

## 8.4 Accent lighting

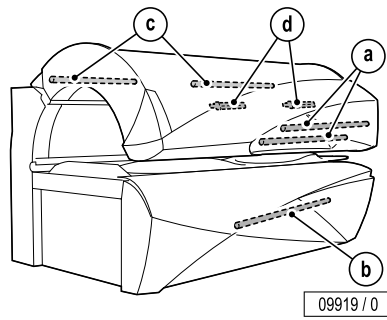

	Number	Description	Power	Order no.
a)	2	Low pressure lamps blue or white	36 W	11792-..
				1002113-..
	2	Decor lighting sleeves yellow or pink or red		1500706-..
			842758-..	
			1500713-..	
	2	Starter S10 (4-65 W)		10047-..
b)	1	Low pressure lamp blue or white	58 W	12063-..
				1002089-..
	1	Decor lighting sleeve yellow or pink or red		1500709-..
			1500712-..	
			1500717-..	
	1	Starter S10 (4-65 W)		10047-..
c)	2	Low pressure lamps blue or white	18 W	11797-..
				1002513-..
	2	Decor lighting sleeves yellow or pink or red		1500708-..
			1500710-..	
			1500716-..	
	2	Starter S10 (4-65 W)		10047-..
d)	2	Low pressure lamps blue	9 W	12262-..



## 8.5 Spare parts and accessories

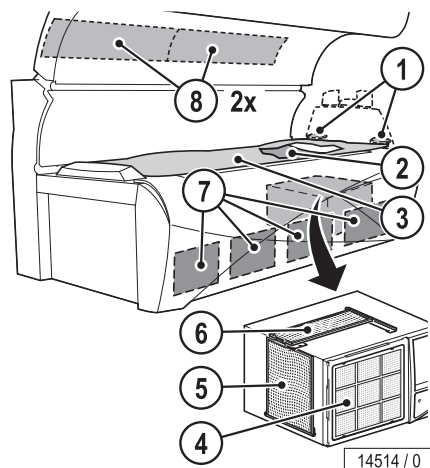

Number	Description	Order no.	
1	2	Filter	800278-..
2	1	Partition	800665-..
3	1	Acrylic panel	1000756-..
4	1	Filter	-
5	1	Filter	51937-..
6	1	Filter	55567-..
7	4	Filter	51937-..
8	2	Filter	800601-..
	1	Protective goggles	0085006152-..
	1	MP3 cable	4630911001-..
	1	Allen-key	83828-..

## 9 JK-Products, Inc. – Limited Warranty

JK-Products, Inc. warrants its products to be free from defects in materials and workmanship under intended normal use as described in the unit's Operation and Instruction Manual, for a period of three (3) years from date of sale.

This Limited Warranty applies only to the original purchaser of the equipment through JK-Products, Inc. or its authorized dealer or distributor, and is not transferable.

Global Service USA obligations under this warranty are limited to repair or replacement of any defective part without charge for that part to the original purchaser, with the following exceptions:

A Fluorescent lamps are warranted against defects for a period of thirty (30) days from date of sale.

B Only parts obtained through JK-Products, Inc., its authorized dealers or distributors may be used. Transportation costs for parts shipped to the consumer and the return of defective parts to Global Service USA are not included.

C Labor will be furnished without charge for ninety (90) days from date of purchase only. All labor and related charges must be authorized by Global Service USA prior to start of repairs, and must coincide with Global Service USA established rates and time allotment policy.

D Acrylic: Refer to Manufacturer's Acrylic Warranty Policy.

It is imperative that the original customer completes and returns the enclosed warranty card within 10 days after purchase to insure valid registration and coverage for potential claims.

If the warranty card is not registered, proof of purchase from JK-Products, Inc. or its authorized dealer or distributor will be required prior to any consideration on warranty claims. This could result in service delays.

This warranty is extended to the individual or legal entity, whose name appears on the warranty registration card filed with Global Service USA, or whose name appears on the original sale document and may not be transferred to any other individual or legal entity.

This warranty does not apply to any failure of the product, or any parts of the product due to alterations, modifications, misuse, abuse, accident, improper maintenance, improper installation, acts of God or if the serial number on the product has been removed, altered or defaced. Adequate packaging must be used for returned goods to prevent freight damage.

**There are no warranties which extend beyond the description on the face hereof. There is no express or implied warranty of fitness of merchantability.**

**The remedies provided in this limited warranty are the exclusive remedies provided to the purchaser by Global Service USA and are provided in substitution of all other remedies. Consequential and incidental damages are excluded.**

No person, firm or corporation is authorized to obligate JK-Products, Inc. for any liability in connection with the sale or use of these goods.

JK Products & Services, Inc. makes no guarantees on income, return on investment, market conditions, performance, etc. with any undertaking using its products and services. Past performance is not indicative of future results.

## 9.1 Limited Acrylic Warranty

---

JK Products, Inc. warrants its acrylic sheets to be free from defects in material and workmanship, under intended normal use, for a period of one (1) year from date of sale of the tanning bed. Due to the tanning lotions, cosmetics, disinfectant and improper cleaners used on tanning surfaces that cannot be controlled by JK Products, Inc., after the first thirty (30) days of warranty period acrylic will be subject to a prorated cost to the consumer.

JK Products, Inc. obligations do not include transportation charges on replacement acrylic.

JK Products, Inc. assumes no liability for the cost of removing defective sheets or installing replacement sheets, or for damage to persons or property.

To make a claim, contact an authorized dealer or distributor of JK-Products, Inc. or Global Service USA with the model number, the serial number, and the date of purchase of the bed in which the acrylic will be used.

**There are no warranties which extend beyond the description on the face hereof. There is no express or implied warranty of fitness or merchantability.**

**The remedies provided in this limited warranty are the exclusive remedies provided to the purchaser by Global Service USA and are provided in substitution of all other remedies. Consequential and incidental damages are excluded.**

JK Products & Services, Inc.  
#1 Walter Kratz Drive  
Jonesboro, AR 72401  
Phone: 800-445-0624 (toll-free)  
Fax: 870-935-9046  
e-mail: support@jkamerica.com  
<http://support.jkamerica.com>

## 9.2 Warranty Claims

---

### 9.2.1 Policy & Procedures

1. When to file a Warranty Claim:

In the event that your tanning system is not functioning properly under intended normal use as described in the unit's Operation and Instruction Manual, you may then have established cause to file a Warranty Claim.



**NOTE:**

Both the tanning system and legal registered owner must meet the criteria established under JK Products, Inc. Limited Warranty as described in this manual before any Warranty Claim will be considered.

2. Where to call to place a Warranty Claim:

JK-Products, Inc. is supported nationwide by an extensive dealer/distributor network through whom the majority of our units are sold. These dealers/distributors are required by contract to stock sufficient parts to meet the various warranty and nonwarranty needs of their customers.

Therefore, in order for you to properly file a Warranty Claim, you must locate the name and phone number of the dealer/distributor through whom you purchased your unit. Normally this information can be easily located either on your paid invoice or other proof of purchase documentation that you received when taking delivery of the unit.

Next, notify the dealer/distributor of the serial number, model number and date unit was purchased. This will initiate the Warranty Claim process.

Upon determination of the problem, your dealer/distributor can then supply you with the part(s) and proper instructions to return your unit to working order.

Each dealer/distributor has their own internal procedure for handling Warranty Claims and credits.



**NOTE:**

JK-Products, Inc., the manufacturer, does not involve itself in the direct handling of a Warranty Claim except where mitigating circumstances apply and where required by law.



**NOTE:**

If part returned to Global Service USA proves to be operational and not defective, or if product code numbers on part do not correspond with individual unit date on file with Global Service USA, then a 30% restocking fee will be charged in addition to the retail purchase price of part.

Acknowledgment of the Agreement is not required for acceptance of the foregoing stipulations.

**9.2.2 Labor Warranty Claim/Credit Procedures**

Global Service USA furnishes labor without charge for a period of 90 days from date of purchase. All labor and related charges must be authorized by Global Service USA prior to start of repairs, and must coincide with Global Service USA established rates and time allotment policy.

Please contact our Service Department for authorization and billing procedures.

## 9.3 Limited Lifetime Warranty

Global Service USA warrants specific individual components of the tanning system against defects in materials and workmanship for the life of the product. Coverage is limited to units purchased after November 1, 1994.

This warranty is restricted to the following components only:

- Steel Back Panels
- Structural Steel Frame Components
- Exterior Steel Body.

**NOTE:**

Components are warranted on an individual basis and not as they may effect the complete product.

Warranty coverage does not include cosmetic abnormalities such as scratches, nicks, dents, rust, oxidation of paint or other cosmetic changes that do not interfere with the designed function of the unit.

This warranty does not include failure of the product due to alteration, modifications, misuse, abuse, improper maintenance, improper installation or repair.

This warranty is not transferable and is only applicable to the original purchaser named on a completed and registered warranty record at JK-Products, Inc. headquarters.

JK Products, Inc. obligations do not include transportation charged on the shipping of new components to the customer or on the return of defective components of the manufacturer. All freight charges must be paid by the customer.

There are no warranties which extend beyond the description on the face hereof. There is no express or implied warranty of fitness or merchantability.

The remedies provided in this limited warranty are the exclusive remedies provided to the purchaser by Global Service USA and are provided in substitution of all other remedies. Consequential and incidental damages are excluded.

**NOTE:**

Any misuse, abuse, modification, alteration, improper maintenance, improper installation, etc. of this product or its intended use will subject said party to direct responsibility and liabilities for any and all consequences resulting from such action. Furthermore, such actions will void all warranties and may relieve Global Service USA of any liabilities relating to said product.

Studio/Salon Name: _____ Contact Name: _____ Street Address: _____ City: _____ Telephone: _____ JK Distributor/Affiliate: _____	Affix Serialized Label Here																
Indicate below that each of the tanning system are in work Lamps: <table border="0"><tr><td>Body</td><td>Feat</td></tr><tr><td><input type="checkbox"/> Base</td><td><input type="checkbox"/></td></tr><tr><td><input type="checkbox"/> Canopy</td><td><input type="checkbox"/></td></tr><tr><td><input type="checkbox"/> Facial Lamps (HPI)</td><td><input type="checkbox"/></td></tr><tr><td><input type="checkbox"/> Facial Lamps</td><td><input type="checkbox"/></td></tr><tr><td><input type="checkbox"/> Spaghettil</td><td><input type="checkbox"/></td></tr><tr><td><input type="checkbox"/> Shoulder Tanner</td><td><input type="checkbox"/></td></tr><tr><td><input type="checkbox"/> Decor</td><td><input type="checkbox"/></td></tr></table>	Body	Feat	<input type="checkbox"/> Base	<input type="checkbox"/>	<input type="checkbox"/> Canopy	<input type="checkbox"/>	<input type="checkbox"/> Facial Lamps (HPI)	<input type="checkbox"/>	<input type="checkbox"/> Facial Lamps	<input type="checkbox"/>	<input type="checkbox"/> Spaghettil	<input type="checkbox"/>	<input type="checkbox"/> Shoulder Tanner	<input type="checkbox"/>	<input type="checkbox"/> Decor	<input type="checkbox"/>	
Body	Feat																
<input type="checkbox"/> Base	<input type="checkbox"/>																
<input type="checkbox"/> Canopy	<input type="checkbox"/>																
<input type="checkbox"/> Facial Lamps (HPI)	<input type="checkbox"/>																
<input type="checkbox"/> Facial Lamps	<input type="checkbox"/>																
<input type="checkbox"/> Spaghettil	<input type="checkbox"/>																
<input type="checkbox"/> Shoulder Tanner	<input type="checkbox"/>																
<input type="checkbox"/> Decor	<input type="checkbox"/>																
By signing below, you confirm stated address, installed, and																	
Signature, JK Dist./Affiliat																	
Signature, Studio/Salon R																	

**BUSINESS REPLY MAIL**  
FIRST-CLASS MAIL PERMIT NO. 295 JONESBORO AR  
POSTAGE WILL BE PAID BY ADDRESSEE  
**J K PRODUCTS & SERVICES**  
1 WALTER KRATZ DIR  
JONESBORO AR 72401-9977

NO POSTAGE  
NECESSARY  
IF MAILED  
IN THE  
UNITED STATES

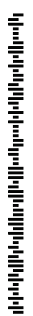

12987 / 0

## 10 Appendix

### 10.1 Signs and stickers on the device

Signs which warn of danger areas are attached to the device. The signs shown below are examples. Ensure that the instruction signs are always clearly recognizable and easily legible. Any missing instruction signs or stickers must be replaced.

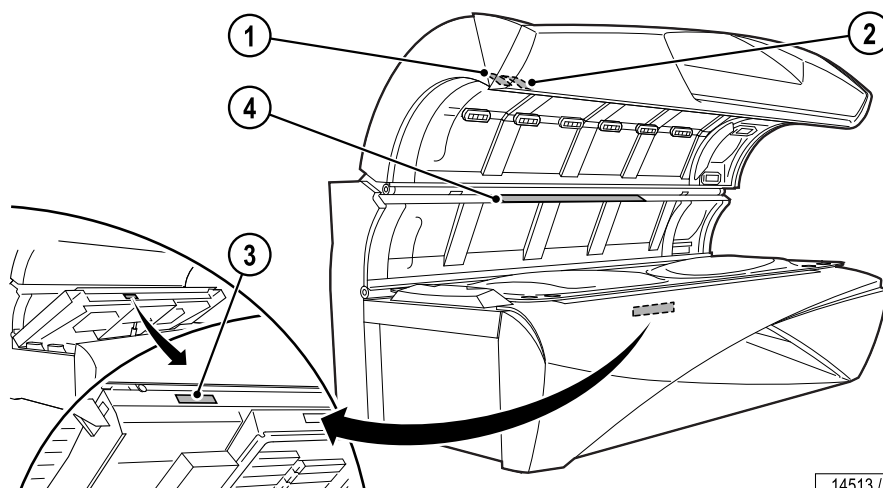

14513 / 0

#### 1: Name plate

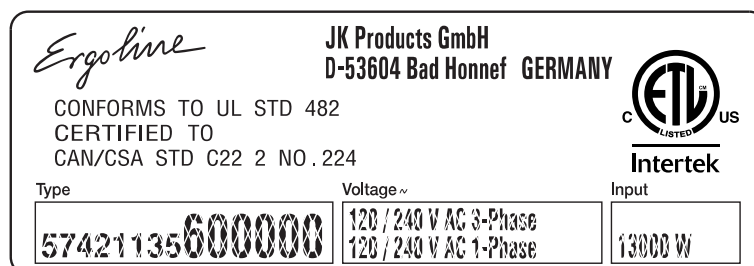

14126 / 1

The name plate is attached to the interior side of the canopy. It contains important information for identifying the device (e. g. the serial number = Serial-No.) and the conformity mark.

#### 2: Module plate

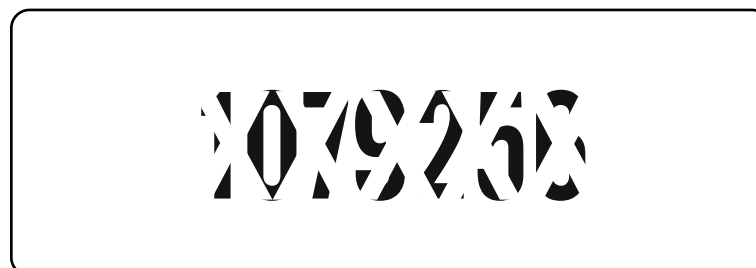

14434 / 0

**3: OEM Parts sticker (801138-..)**

**ATTENTION!**

Only use OEM certified replacement parts.  
The use of other parts voids all  
manufacturer's warranties and responsibilities.

801138-00-

13513 / 0

The sticker is mounted on the bottom edge at the front of the bed base.

**4: Exposure label**

<p style="text-align: center;"><b>DANGER ULTRAVIOLET RADIATION</b></p> <p>Follow instructions. Avoid over-exposure as with natural sunlight. Over-exposure can cause eye and skin injury and allergic reactions. Repeated exposure may cause premature aging of the skin and skin cancer.</p> <p style="font-size: 1.2em; font-weight: bold;">Maximum Tanning Time is 12 Minutes</p>	<p style="text-align: center;"><b>Recommended Exposure Schedule</b></p> <table border="1" style="width: 100%; border-collapse: collapse; text-align: center;"> <thead> <tr> <th style="text-align: left;">Skin Type</th> <th>Week 1 1st - 3rd Treatments</th> <th>Week 2 4th - 6th Treatments</th> <th>Week 3 7th - 10th Treatments</th> <th>Week 4 11th - 15th Treatments</th> <th>Weekly Subsequent Treatments</th> </tr> </thead> <tbody> <tr> <td style="text-align: left;">I - Sensitive</td> <td>NOT ADVISED</td> <td>NOT ADVISED</td> <td>NOT ADVISED</td> <td>NOT ADVISED</td> <td>NOT ADVISED</td> </tr> <tr> <td style="text-align: left;">II - Fair</td> <td>2 Min.</td> <td>5 Min.</td> <td>8 Min.</td> <td>10 Min.</td> <td>12 Min.</td> </tr> <tr> <td style="text-align: left;">III - Average</td> <td>2 Min.</td> <td>5 Min.</td> <td>8 Min.</td> <td>10 Min.</td> <td>12 Min.</td> </tr> <tr> <td style="text-align: left;">IV - Brown</td> <td>2 Min.</td> <td>7 Min.</td> <td>10 Min.</td> <td>12 Min.</td> <td>12 Min.</td> </tr> <tr> <td style="text-align: left;">V - Dark Brown</td> <td>2 Min.</td> <td>7 Min.</td> <td>10 Min.</td> <td>12 Min.</td> <td>12 Min.</td> </tr> </tbody> </table>	Skin Type	Week 1 1st - 3rd Treatments	Week 2 4th - 6th Treatments	Week 3 7th - 10th Treatments	Week 4 11th - 15th Treatments	Weekly Subsequent Treatments	I - Sensitive	NOT ADVISED	NOT ADVISED	NOT ADVISED	NOT ADVISED	NOT ADVISED	II - Fair	2 Min.	5 Min.	8 Min.	10 Min.	12 Min.	III - Average	2 Min.	5 Min.	8 Min.	10 Min.	12 Min.	IV - Brown	2 Min.	7 Min.	10 Min.	12 Min.	12 Min.	V - Dark Brown	2 Min.	7 Min.	10 Min.	12 Min.	12 Min.
Skin Type	Week 1 1st - 3rd Treatments	Week 2 4th - 6th Treatments	Week 3 7th - 10th Treatments	Week 4 11th - 15th Treatments	Weekly Subsequent Treatments																																
I - Sensitive	NOT ADVISED	NOT ADVISED	NOT ADVISED	NOT ADVISED	NOT ADVISED																																
II - Fair	2 Min.	5 Min.	8 Min.	10 Min.	12 Min.																																
III - Average	2 Min.	5 Min.	8 Min.	10 Min.	12 Min.																																
IV - Brown	2 Min.	7 Min.	10 Min.	12 Min.	12 Min.																																
V - Dark Brown	2 Min.	7 Min.	10 Min.	12 Min.	12 Min.																																

<p><b>WEAR PROTECTIVE EYEWEAR! Failure to do so may result in severe burns or long term injury to the eyes.</b></p> <p>Certain medications or cosmetics may increase your sensitivity to the ultraviolet radiation. Consult a physician before using sunlamps if you are using medication, have a history of skin problems or believe yourself to be especially sensitive to sunlight. If you do not tan in the sun, you are unlikely to tan from the use of this product.</p>	<p>This unit utilizes UVA lamps. Replace only with Ergoline VHP 12 PREMIUM 160W Turbo Power, Ergoline VHP 25W Power (shoulder-/ neck-tanner) and Ergoline ultra 520W C12645 (high pressure) or recognized equivalents. To obtain recommended exposure at a minimum distance of 1/2" (13mm) measured with a standard ruler, lie on acrylic surface of lounge and lower canopy. Canopy will stop at the correct distance from lounge acrylic surface.</p> <p><b>Warning: The use of any other position may result in overexposure!</b></p>
--	--

<p>Tanning can begin on a regular basis. An appearance of tanning normally appears after a few exposures and maximizes after four (4) weeks of exposure following the recommended exposure schedule for skin type. In order to provide for maintenance of a tan a maximum of two (2) weekly 12 minute sessions is recommended from the fifth week onward.</p> <p><b>Do not tan more than once in a 24 hour period.</b></p>	<p>Use protective eyewear (Part No. Schmerler 2255 Red or recognized equivalents) when equipment is on. Read and follow instruction booklet before using this product. To avoid electrical shock during maintenance disconnect power from unit.</p> <p style="text-align: right;">Part No: 801642a</p>
--	--

10000 / 0



## USA mains connection sticker

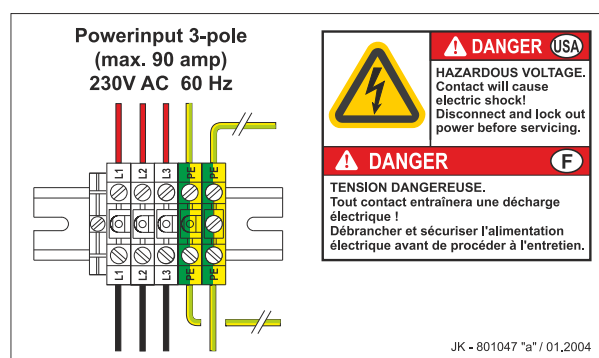

04605 / 2

The sticker is mounted on the rear panel at the left.

## Air conditioning sticker (1001372-..)

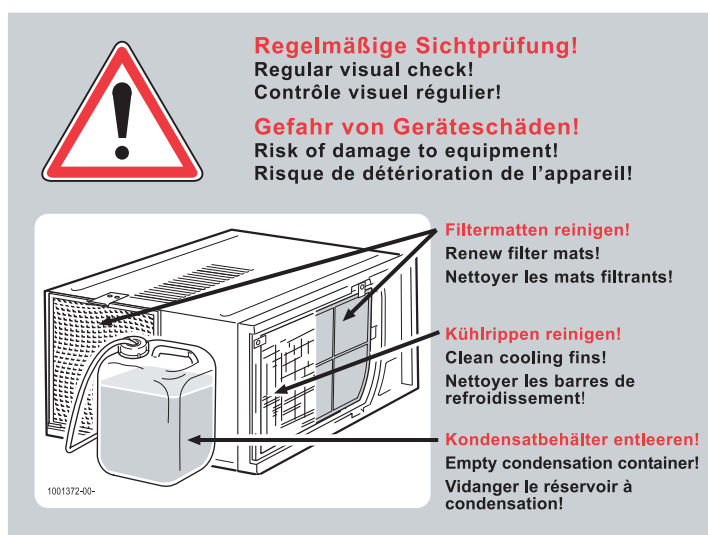

11984 / 0

The sticker is mounted on the air conditioning.

# 11 Index

- A**
- Accent lighting ..... 54
  - Accessories ..... 17, 55
  - Acrylic glass (maintenance) ..... 27
  - Acrylic panel  
(product information) ..... 30
  - Acrylic panel, load ..... 51
  - Adolescents ..... 12, 18
  - Assembly ..... 13
- C**
- Changing the starter ..... 38
  - Cleaning ..... 25, 27
    - Air conditioning ..... 48
    - Air conditioning filter ..... 48
    - Filter ..... 45
    - Filter mats ..... 46, 47
    - Lamps, filter panels ..... 28
  - Cleaning / replacing the  
UV lamps
    - Base ..... 40
    - Canopy ..... 41
    - Shoulder tanner ..... 42
    - Side section ..... 41
  - Cleaning intervals ..... 28
  - Cleaning or replacing the  
accent lighting
    - Canopy ..... 44
    - Front panel ..... 44
  - Cleaning or replacing the  
interior lighting ..... 42
  - Cleaning overview ..... 28
  - Cleaning the filter ..... 45, 46, 47
  - Cleaning/replacing
    - Ambient Light ..... 45
  - Connect MP3 player ..... 24
  - Contact lenses ..... 19
  - Copy protection ..... 14
- D**
- Decor lighting sleeves ..... 38
  - Definitions ..... 7
  - Description ..... 16
  - Device description ..... 16
  - Dimensions ..... 52
  - Disinfection ..... 27
  - Disposal ..... 14
- E**
- Electric shock ..... 9
  - Electrical specifications ..... 51
  - Electrician ..... 7
  - Empty the condensation tank ... 48
  - Equipment ..... 15
  - Exhaust air ventilation ..... 13
  - Export ..... 13
  - Eye damage ..... 18
- F**
- Facial tanner
    - Cleaning/replacing ..... 41
  - Fault codes ..... 26
  - Faults ..... 26
  - Filter panels ..... 39
    - Cleaning/replacing ..... 41
  - Foreseeable misuse ..... 12
  - Functions ..... 21
- G**
- Glasses ..... 19
  - Guidelines ..... 13
- H**
- High pressure lamps,  
danger of fire! ..... 39
- I**
- Injury ..... 9
  - Installed lamps ..... 53
  - Instruction signs ..... 14
  - Intended use ..... 12
  - Itching ..... 18
- L**
- Lamp configuration ..... 53
  - Lamps ..... 12

Lift up the acrylic panel .....33  
Light sensitivity..... 18

## M

Maintenance .....25, 27, 29  
Maintenance overview .....30  
Make-up .....19  
Medications..... 18  
MP3 music ..... 14

## O

Open the bed base .....36  
Operating overview .....20  
Operator .....7  
Operator's obligations ..... 12

## P

Plastic surfaces  
(maintenance) .....27  
Play rights ..... 14  
Power rating.....51  
Product information ..... 12  
Protective measures when  
performing maintenance  
work .....25

## Q

Qualified staff .....7

## R

Recycling ..... 14  
Remove the canopy panel .....34  
Remove the side section  
panel .....35

Replace the UV low pressure  
lamps .....37  
Replacing the lamps .....37  
Risk of injury ..... 18

## S

Safety notices .....9  
Scope of delivery ..... 15  
Setup..... 13  
Sickness..... 18  
Skin types .....6  
Spare parts .....30, 55  
Staff.....7  
Staff training ..... 13  
Start tanning.....23  
Start-up settings .....23  
Sunburn ..... 18

## T

Tanning times .....6  
Technical Service.....2  
Transport..... 13

## U

UV lamps .....53

## V

Ventilation ..... 13

## W

Warning signs, description .....8









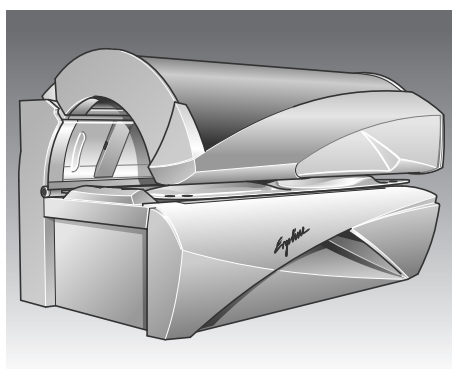

*Ergoline*

**AFFINITY 950** ULTRA POWER  
TEMPTRONIC

**JK-Products & Services, Inc.**

1 Walter Kratz Drive  
Jonesboro, AR 72401

Phone: 800.643.0086 (Toll-free)

Fax: 870.935.3618

Website: [www.sunergoline.com](http://www.sunergoline.com)

E-Mail: [ergoline@sunergoline.com](mailto:ergoline@sunergoline.com)